



WCPS-B, WCPS-FB Series 50Hz

Water Cooled Packaged Units
Cooling Capacity: 5 to 127 TR (18 to 447 kW)



WCPS-FB



WCPS-B

R₂₂
R_{407C}

DUNHAM-BUSH

Products that perform...By people who care

NOMENCLATURE

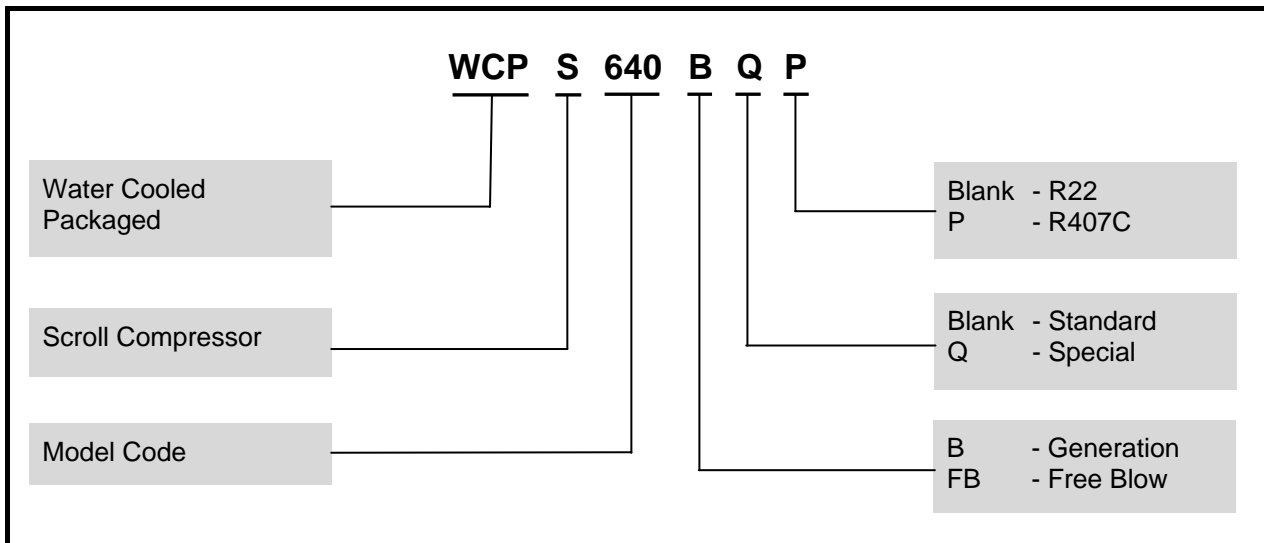

WATER COOLED PACKAGED UNITS

GENERAL DESCRIPTION

The WCPS series with new features is suitable for hotel, office, hospital, factory and supermarket applications. The low noise and compact series are completely leak tested, evacuated, dehydrated and precharged with refrigerant so that it is ready for connection when reached the site.

Scroll Compressor(s)

Reliability

- ✦ No contact scroll design that minimizes friction, increases volumetric efficiency and reduces vibration, thus longer service life.
- ✦ Suction gas cooled motor.

Low Power Consumption:

- ✦ High EER.
- ✦ No crankcase heater required.



Tandem Compressor (WCPS 480B to 1520B)

For model with 3 compressors system and above, two compressors are connected in tandem, thus reducing the number of condenser water inlet/outlet connection.



Multiple Compressor (WCPS 220B to 1520B)

- ✦ By cycling off compressor(s) operation to match building load, no energy is being wasted when room load requires lesser cooling capacity.
- ✦ No total shut down when servicing or repairing a faulty compressor.

WATER COOLED PACKAGED UNITS

Cleanable Shell and Tube Condenser

- ✦ Multiple 3/4"[19mm] O.D. copper finned tubes with 25 to 30% more surface area ensure better heat transfer.
- ✦ Integral subcooling circuit to maximize efficiency.
- ✦ Provided with fusible plug for safety purpose.
- ✦ Leak and pressure tested to 450 psig [31 bar].



noise level and eliminates the need for common transition and eliminates air unbalance.

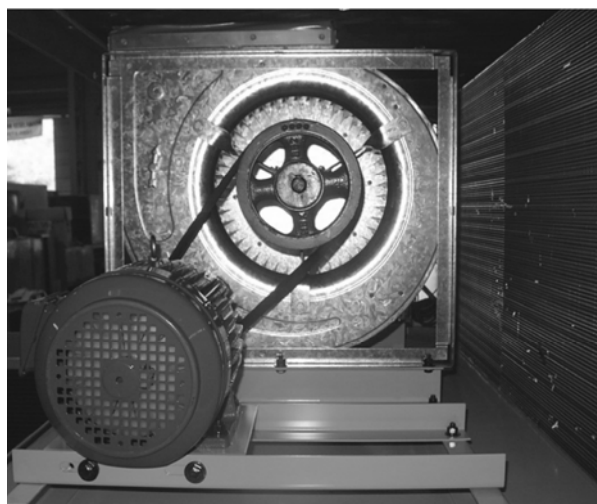

Fully Leak Tested Refrigerant Circuit

- ✦ Leak and pressure tested at 450psig [31bar].
- ✦ Pressure ports are provided on the discharge, liquid and suction line.
- ✦ Evacuated, dehydrated and charged with refrigerant.

Safety Components

- ✦ High-low pressure cutout to protect compressor from high discharge pressure and system leakage.
- ✦ Liquid line sight glass and filter drier for refrigerant line components.

Efficient Evaporator Coil

- ✦ Independent thermal expansion valve with external equalizer for better refrigerant control and wider load condition.
- ✦ Leak and pressure tested to 450psig [31bar].
- ✦ Evacuated, dehydrated and charged with refrigerant.

Drive Package and Blowers (WCPS 108B to 1520B)

- ✦ Belt driven drive package offers flexibility on various air flow rate and various static pressure applications.
- ✦ Single large diameter double inlet double width blowers (AMCA certified) reduce the

Casing

- ✦ Constructed of heavy gauge steel sheet and insulated with 1/2" [13mm] thick x 1 1/2 lb per cu.ft [24kg per cu meter] linacoustic fiberglass.
- ✦ Aesthetically coated with powder paint to provide excellent finish, weatherability and corrosion resistance.
- ✦ Removable panels on the left and right hand side of the unit to provide access to critical parts and components.

Filters

1" [25mm] thick washable filters.

Optional Accessories Features

- ✦ Factory wired starters
 - DOL for compressors and fan motors.
 - Auto-transformer for compressors.
- ✦ Suction stop valve(s), discharge stop valve(s) and liquid stop valve(s).
- ✦ Thermostat.
- ✦ Hydrophilic aluminium fins or copper fins or ADSIL coated copper fins for better corrosion resistance.
- ✦ Hot gas by pass for low load conditions.
- ✦ Hot water heating coils.
- ✦ Electric heaters.



PHYSICAL SPECIFICATIONS

Model	Compressor					Cond.*	Blower Section					Evaporator Coil		Filters Charge		Approx. Refrigerant Charge	Approx. Operating Weight	
	Qty	MRA	LRA	R22	R407C		Blower	Motor			Fan Air Flow	Rows Deep	Total Face Area ft²[m²]	Qty	Size inches[mm]			
				NRA (400V)	NRA (400V)	Max HP		FLA	LRA	Min Max cfm[m³/hr]						Comp. Qty x lbs[kg]	lbs[kg]	
WCPS 68B	1	1x14.0	1x74	1x7.8	1x8.2	7[1.6] 24[5.4]	1	10x10	1	-	-	-	3	5.2 [0.5]	1	16x25[406x635] 20x25[508x635]	1x8.3[3.8]	635 [288]
WCPS 81B	1	1x17.0	1x101	1x8.8	1x9.1	8[1.8] 29[6.6]	1	12x12	1	-	-	-	3	5.7 [0.5]	1	16x25[406x635] 20x25[508x635]	1x9.9[4.5]	762 [346]
WCPS 95B	1	1x23.0	1x95	1x12.0	1x13.0	9[2.0] 33[7.5]	1	12x12	1	-	-	-	3	6.1 [0.6]	1	16x25[406x635] 20x25[508x635]	1x12.3[5.8]	840 [381]
WCPS 108B	1	1x24.2	1x114	1x12.4	1x13.1	11[2.5] 38[8.6]	1	12x12	3	4.85	38.2	1980[3364] 4355[7400]	3	6.6 [0.6]	4	25x25[635x635] 20x25[508x635]	1x13.2[6.0]	975 [442]
WCPS 125B	1	1x26.9	1x125	1x14.1	1x14.7	13[3.0] 44[10.0]	1	12x12	4	6.4	41.7	2250[3823] 4125[7009]	3	7.6 [0.7]	2	16x16[406x406] 16x20[406x508]	1x17.6[8.0]	1350 [612]
WCPS 145B	1	1x27.5	1x125	1x15.6	1x16.0	15[3.4] 51[11.6]	1	12x12	4	6.4	41.7	2380[4044] 4355[7400]	4	7.6 [0.7]	2	16x16[406x406] 16x20[406x508]	1x16.0[7.3]	1368 [621]
WCPS 160B	1	1x34.0	1x167	1x18.0	1x18.9	16[3.6] 56[12.7]	1	12x12	4	6.4	41.7	2380[4044] 4355[7400]	3	11.3 [1.0]	2	16x25[406x635] 20x25[508x635]	1x23.8[10.8]	1397 [634]
WCPS 190B	1	1x37.0	1x198	1x24.6	1x26.6	19[4.3] 67[15.2]	1	15x15	7.5	11.3	77.5	3970[6746] 7270[12353]	3	12.0 [1.1]	2	16x25[406x635] 20x25[508x635]	1x25.3[11.5]	1750 [794]
WCPS 220B	1	1x23.0 1x26.9	1x95 1x125	1x12.0 1x14.1	1x13.0 1x14.7	22[5.0] 76[17.3]	1	15x15	7.5	11.3	77.5	4600[7816] 8440[14341]	3	15.1 [1.4]	4	16x25[406x635] 16x20[406x508]	1x13.3[6.0] 1x17.6[8.0]	1880 [853]
WCPS 250B	2	2x26.9	2x125	2x14.1	2x14.7	25[5.7] 88[20.0]	1	15x15	7.5	11.3	77.5	4960[8428] 9090[15446]	3	16.3 [1.5]	2 1 1	16x25[406x635] 20x25[508x635] 20x20[508x508] 16x20[406x508]	2x17.6[8.0]	1980 [898]
WCPS 290B	2	1x26.9 1x34.0	1x125 1x167	2x15.6	2x16.0	29[6.6] 100[22.7]	1	18x13	15	21.5	145.4	6020[10229] 11040[18759]	3	19.8 [1.8]	3 2 1	20x25[508x635] 25x25[635x635] 20x20[508x508]	1x17.6[8.0] 1x23.8[10.8]	2375 [1077]
WCPS 320B	2	2x34.0	2x167	2x18.0	2x18.9	32[7.3] 112[25.4]	1	18x13	15	21.5	145.4	6375[10832] 11690[19864]	3	20.9 [1.9]	3 2 1	20x25[508x635] 25x25[635x635] 20x20[508x508]	2x23.8[10.8]	2700 [1225]
WCPS 380B	2	2x37.0	2x198	2x24.6	2x26.6	38[8.6] 133[30.2]	1	18x18	15	21.5	145.4	6375[10832] 11690[19864]	4	20.9 [1.9]	3 2 1	20x25[508x635] 25x25[635x635] 20x20[508x508]	2x25.3[11.5]	3150 [1429]
WCPS 435B	3	2x34.0 1x27.5	2x167 1x125	3x15.6	3x16.0	45[10.2] 156[35.4]	1	18x18	20	29.2	199.5	7080[12030] 13000[22090]	4	23.6 [2.2]	2 2 4	20x25[508x635] 25x25[635x635]	1x17.6[8.0] 2x23.8[10.8]	3372 [1530]
WCPS 480B	3	3x34.0	3x167	3x18.0	3x18.9	48[10.9] 168[38.1]	1	20x20	20	29.2	199.5	9000[15293] 16500[28037]	3	30.0 [2.8]	9	20x25[508x635]	3x23.8[10.8]	4264 [1934]
WCPS 510	2	2x34.0 1x37.0	2x167 1x198	2x18.0 1x24.6	2x18.9 1x26.6	51[11.6] 178[40.4]	1	22x22	20	29.2	199.5	9000[15293] 16500[28037]	3	30.0 [2.8]	9	20x25[508x635]	2x23.8[10.8] 1x25.3[11.5]	4264 [1934]
WCPS 570B	3	3x37.0	3x198	3x24.6	3x26.6	57[12.9] 200[45.4]	1	22x22	20	29.2	199.5	9000[15293] 16500[28037]	4	30.0 [2.8]	9	20x25[508x635]	3x25.3[11.5]	4640 [2105]
WCPS 640B	4	4x34.0	4x167	4x18.0	4x18.9	64[14.5] 224[50.8]	1	22x22	30	41.2	274.6	10800[18351] 19800[33644]	4	36.0 [3.3]	9	25x25[635x635]	4x23.8[10.8]	6260 [2840]
WCPS 700B	2	2x34.0 2x37.0	2x167 2x198	2x18.0 2x24.6	2x18.9 2x26.6	70[15.9] 245[55.6]	1	22x22	30	41.2	274.6	11500[19541] 21200[36023]	4	37.9 [3.5]	12	20x25[508x635]	2x23.8[10.8] 2x25.3[11.5]	6300 [2858]
WCPS 760B	4	4x37.0	4x198	4x24.6	4x26.6	76[17.3] 266[60.4]	1	25x25	30	41.2	274.6	12200[20730] 32340[54952]	4	40.6 [3.8]	12	20x25[508x635]	4x25.3[11.5]	6521 [2958]
WCPS 800B	5	5x34.0	5x167	5x18.0	5x18.9	80[18.2] 280[63.6]	1	25x25	40	55.6	375.2	16150[27442] 29620[50330]	3	50.6 [4.7]	6 2 2	16x25[406x635] 16x20[406x508] 25x25[635x635] 20x25[508x635]	5x23.8[10.8]	6972 [3162]
WCPS 860B	2	2x37.0 3x34.0	2x198 3x167	3x18.0 2x24.6	3x18.9 2x26.6	89[20.2] 312[70.8]	1	28x28	40	55.6	375.2	16150[27442] 29620[50330]	3	50.6 [4.7]	6 2 2	16x25[406x635] 16x20[406x508] 25x25[635x635] 20x25[508x635]	3x23.8[10.8] 2x25.3[11.5]	7480 [3393]
WCPS 950B	5	5x37.0	5x198	5x24.6	5x26.6	96[21.8] 336[76.3]	1	28x28	40	55.6	375.2	16150[27442] 29620[50330]	4	50.6 [4.7]	6 2 2	16x25[406x635] 16x20[406x508] 25x25[635x635] 20x25[508x635]	5x25.3[11.5]	7750 [3515]
WCPS 1140B	6	6x37.0	6x198	6x24.6	6x26.6	114[25.9] 399[90.6]	2	22x22	50	67.4	464.6	20000[33984] 36770[62480]	4	70.8 [6.6]	2 10 8	20x20[508x508] 25x20[635x508] 25x25[635x635]	6x25.3[11.5]	8790 [3987]
WCPS 1340B	2	2x37.0 6x34.0	2x198 6x167	2x18.0 6x24.6	2x18.9 6x26.6	134[30.4] 469[106.4]	2	22x22	50	67.4	464.6	21200[36023] 38870[66048]	4	70.8 [6.6]	2 10 8	20x20[508x508] 25x20[635x508] 25x25[635x635]	6x23.8[10.8] 2x25.3[11.5]	9122 [4138]
WCPS 1520B	8	8x37.0	8x198	8x24.6	8x26.6	152[34.5] 532[120.8]	2	22x22	50	67.4	464.6	21200[36023] 38870[66048]	5	70.8 [6.6]	2 10 8	20x20[508x508] 25x20[635x508] 25x25[635x635]	8x25.3[11.5]	9240 [4191]

* Condenser type: Cleanable shell and tubes.

- Notes:**
- 1.) LRA = Locked rotor ampere.
 - 2.) NRA = Nominal running ampere.
 - 3.) FLA = Full load ampere.
 - 4.) MRA = Maximum running ampere.
 - 5.) All rating is based on 400V-3-50Hz.
 - 6.) Minimum-maximum voltage is 360V-440V.
 - 7.) Filter is one inch thick.
 - 8.) Blower for model WCPS 68B to 95B as direct driven.
 - 9.) For other power supply requirements, please contact the Dunham-Bush sales office.



PHYSICAL SPECIFICATIONS

WCPS FREE BLOW UNITS

Model WCPS	Compressor					Cond.	Blower Section						Evaporator Coil		Filters		Comp. Ref. Charge Qty x lbs[kg]	
	Qty	MRA	LRA	R22	R407C		Blower			Motor			Fan Air Flow		Qty	Size inches[mm]		
				NRA (400V)	NRA (400V)		Type Of Drv.	Qty	Dia x Width inches	Max. HP	FLA EA.	LRA EA.	Min-Max cfm[m³/hr]	Rows Deep				Total Face Area ft²[m²]
68FB	1	1x14.0	1x74	1x7.8	1x8.2	7[1.6] 24[5.5]	Direct	1	9x9	0.5	3.5	-	2000[3398]	3	5.4[0.5]	2	20 7/8 x 18 1/8 x 1/2 [530x460x13]	1x8.3[3.8]
81FB	1	1x17.0	1x101	1x8.8	1x9.1	8[1.8] 29[6.6]	Direct	2	9x7	0.5	3.5	-	2400[4078]	3	7.0[0.7]	2	20 7/8 x 18 1/8 x 1/2 [530x460x13]	1x9.9[4.5]
95FB	1	1x23.0	1x95	1x12.0	1x13.0	9 [2.0] 33[7.5]	Direct	2	9x7	0.5	3.5	-	2800[4758]	4	7.0[0.7]	2	20 7/8 x 18 1/8 x 1/2 [530x460x13]	1x12.3[5.6]
125FB	1	1x26.9	1x125	1x14.1	1x14.7	13[3.0] 44[10.0]	Belt	2	10x10	1.0	2.0	10.4	4000[6797]	3	9.9[0.9]	2	27 3/4 x 18 1/8 x 1/2 [705x460x13]	1x17.6[8.0]
145FB	1	1x27.5	1x125	1x15.6	1x16.0	15[3.4] 51[11.6]	Belt	2	10x10	1.5	2.8	15.4	4400[7476]	4	9.9[0.9]	2	27 3/4 x 18 1/8 x 1/2 [705x460x13]	1x16.0[7.3]
160FB	1	1x34.0	1x167	1x18.0	1x18.9	16[3.6] 56[12.7]	Belt	2	10x10	1.5	2.8	15.4	4600[7816]	4	9.9[0.9]	2	27 3/4 x 18 1/8 x 1/2 [705x460x13]	1x23.8[10.8]
190FB	2	1x17.0 1x23.0	1x101 1x95	1x8.8 1x12.0	1x9.1 1x13.0	19[4.3] 67[15.2]	Belt	2	12x12	2.0	3.5	20.2	5800[9855]	3	13.1[1.2]	2	32 5/8 x 18 1/8 x 1/2 [829x460x13]	1x25.3[11.5]
220FB	1	1x23.0 1x26.9	1x95 1x125	1x12.0 1x14.1	1x13.0 1x14.7	22[5.0] 76[17.3]	Belt	2	12x12	2.0	3.5	20.2	6400[10875]	4	13.1[1.2]	2	32 5/8 x 18 1/8 x 1/2 [829x460x13]	2x13.2[6.0]

* Condenser type: Cleanable shell and tubes.

- Notes: 1.) MRA = Maximum running ampere
 2.) LRA = Locked rotor ampere.
 3.) NRA = Nominal running ampere.
 4.) FLA = Full load ampere.

5.) Minimum-maximum voltage is 360V-440V. All ratings are based on 400V-3-50Hz.

6.) For WCPS 68FB to 95FB, Blower fan motor shall be 230V-1-50Hz. For WCPS 125FB to 220FB blower fan shall be 400V-3-50Hz.

7.) For other power supply requirements, please contact the Dunham-Bush sales office.

SYSTEM COOLING CAPACITY

PERFORMANCE DATA

R22

Model	Standard Capacity MBH	Air On Evap.		Water Temperature Off Condenser - °F								
		CFM	WB Temp. °F	80			95			110		
				Total MBH¹	Sens MBH²	kW³	Total MBH¹	Sens MBH²	kW³	Total MBH¹	Sens MBH²	kW³
WCPS 68B	68	2000	72	76.5	40.7	3.2	72.1	38.3	3.5	65.1	34.6	3.6
			67	73.0	54.1	3.1	68.0	50.4	3.4	64.4	47.8	3.6
			62	66.6	66.6	3.1	61.5	61.5	3.3	58.8	58.8	3.5
			57	58.8	58.8	3.1	54.4	54.4	3.3	51.7	51.7	3.5
WCPS 81B	81	2400	72	91.1	44.3	3.8	85.8	41.4	4.1	74.5	39.3	4.2
			67	86.9	56.4	3.6	81.0	54.2	4.0	76.8	52.6	4.1
			62	79.3	67.8	3.6	73.3	65.3	3.9	70.0	63.5	4.1
			57	70.0	70.0	3.5	64.8	64.8	3.9	61.5	61.5	4.1
WCPS 95B	95	2800	72	106.9	57.0	4.7	100.7	53.6	5.1	90.9	50.7	5.3
			67	101.9	75.8	4.5	95.0	70.8	5.0	90.1	67.0	5.2
			62	93.1	92.4	4.5	87.1	86.6	4.8	82.2	82.2	5.1
			57	82.3	82.3	4.4	76.1	76.1	4.8	72.2	72.2	5.1
WCPS108B	108	3500	72	121.6	64.8	5.3	114.5	61.1	5.6	108.0	57.6	5.9
			67	115.9	86.2	5.1	108.0	80.4	5.6	102.4	76.2	5.9
			62	105.9	105.1	5.0	99.1	98.4	5.5	93.5	93.5	5.7
			57	93.5	93.5	5.0	86.6	86.6	5.4	82.1	82.1	5.7
WCPS125B	125	3800	72	140.7	75.4	6.2	132.5	71.0	6.7	125.0	67.0	7.0
			67	134.1	99.6	5.9	125.0	92.8	6.5	118.4	87.9	6.8
			62	122.4	121.3	5.9	114.6	113.6	6.4	108.1	108.1	6.7
			57	108.1	108.1	5.8	100.3	100.3	6.4	95.0	95.0	6.7
WCPS 145B	145	4000	72	163.2	76.9	7.1	153.7	72.4	7.6	145.0	68.3	8.0
			67	155.6	101.5	6.7	145.0	94.6	7.4	137.3	89.6	7.7
			62	142.0	123.7	6.7	132.9	115.8	7.3	125.4	110.2	7.6
			57	125.4	110.2	6.6	116.3	102.2	7.3	110.2	96.8	7.6
WCPS 160B	160	4200	72	179.9	102.7	8.0	169.5	96.7	8.6	159.9	91.1	8.9
			67	171.6	139.1	7.8	160.0	129.6	8.4	151.7	122.9	8.8
			62	156.6	156.6	7.7	146.7	146.7	8.2	138.3	138.3	8.6
			57	138.3	138.3	7.4	127.9	127.9	8.2	121.6	121.6	8.6
WCPS 190B	190	5800	72	213.7	84.5	9.2	201.4	107.2	9.9	190.0	101.1	10.2
			67	203.8	150.1	8.7	190.0	139.9	9.6	180.1	132.6	10.0
			62	186.0	182.6	8.7	174.1	171.0	9.3	164.3	164.3	9.9
			57	163.6	163.6	8.5	152.3	152.3	9.3	144.4	144.4	9.9
WCPS 220B	220	6400	72	248.8	144.6	10.9	234.5	136.3	11.9	220.0	127.8	12.2
			67	233.4	192.9	10.4	220.0	181.8	11.5	206.6	170.7	12.0
			62	215.6	215.6	10.4	204.4	204.4	11.1	178.0	178.0	11.9
			57	195.6	195.6	10.2	173.4	173.4	11.1	170.0	170.0	11.9
WCPS 250B	250	6800	72	281.2	148.5	12.4	264.9	139.8	13.5	249.9	131.9	13.8
			67	265.2	194.7	11.8	250.0	183.5	13.0	236.9	174.0	13.6
			62	244.6	230.2	11.8	228.3	228.3	12.6	216.2	216.2	13.5
			57	222.1	222.1	11.6	200.4	200.4	12.6	189.9	189.9	13.5

Notes: 1.) Ratings are gross capacities. For net capacities, deduct evaporator blower motor heat.

2.) At 80°F (26.6°C) DB air on evaporator.
 3.) Compressor kW input.



SYSTEM COOLING CAPACITY

PERFORMANCE DATA

R22

Model	Standard Capacity MBH	Air On Evap.		Water Temperature Off Condenser - °F								
		CFM	WB Temp. °F	80			95			110		
				Total MBH'	Sens MBH²	kW³	Total MBH'	Sens MBH²	KW³	Total MBH'	Sens MBH²	kW³
WCPS 290B	288	7800	72	325.9	163.7	13.9	307.0	154.2	14.8	290.1	144.7	15.7
			67	305.6	210.0	13.8	288.0	198.0	14.6	270.6	186.0	15.6
			62	282.2	252.9	13.6	267.7	239.9	14.6	250.2	224.2	15.5
			57	256.1	256.1	13.5	241.5	241.5	14.4	224.0	224.0	15.4
WCPS 320B	320	8400	72	362.1	180.8	15.9	341.1	170.3	17.2	320.1	159.9	17.7
			67	343.5	230.3	15.1	320.0	217.0	16.7	300.7	203.9	17.5
			62	313.4	275.8	15.1	297.5	261.3	16.2	278.1	244.6	17.2
			57	284.5	284.5	14.9	268.4	268.4	16.2	260.0	260.0	17.2
WCPS 380B	380	10500	72	427.4	221.9	18.2	405.9	209.1	19.7	380.0	197.4	20.3
			67	407.7	292.5	17.3	380.0	272.6	19.1	360.2	258.5	20.0
			62	371.9	353.9	17.3	348.4	331.6	18.5	328.6	312.8	19.7
			57	328.6	328.6	17.0	318.5	318.5	18.5	308.0	308.0	19.7
WCPS 435B	435	11500	72	470.5	236.8	21.5	443.2	223.0	22.9	415.8	209.2	24.2
			67	441.1	354.7	21.4	435.0	285.7	22.7	390.6	268.4	24.1
			62	407.4	366.6	21.0	386.4	347.6	22.6	361.2	324.9	23.9
			57	369.7	369.7	20.9	348.7	348.7	22.3	342.1	342.1	23.8
WCPS 480B	480	13500	72	543.0	271.5	23.8	511.4	255.8	25.3	479.9	240.0	26.8
			67	509.0	344.6	23.6	480.0	325.1	25.1	450.8	305.4	26.7
			62	470.2	414.3	23.2	445.9	393.0	24.9	416.9	367.3	26.5
			57	426.6	426.6	23.0	402.4	402.4	24.7	396.0	396.0	26.3
WCPS 510B	510	14500	72	577.0	288.5	25.0	543.5	271.8	26.5	510.0	255.0	28.1
			67	540.9	366.2	24.7	510.0	345.5	26.3	479.1	324.5	28.0
			62	499.7	440.3	24.4	473.9	417.6	26.1	443.0	390.3	27.8
			57	453.3	453.3	24.1	427.6	427.6	25.9	420.0	420.0	27.6
WCPS 570B	570	15500	72	645.0	324.0	27.2	607.6	305.2	28.9	570.1	286.3	30.7
			67	604.7	414.4	27.0	570.0	397.4	28.7	535.5	367.1	30.6
			62	558.6	500.5	26.6	529.8	474.7	28.5	495.2	443.7	30.4
			57	506.8	506.8	26.4	478.0	478.0	28.3	470.0	470.0	30.1
WCPS 640B	640	17000	72	724.0	360.4	31.7	682.0	339.5	33.6	640.0	318.6	35.8
			67	678.8	458.8	31.5	640.0	429.7	33.4	601.2	403.7	35.5
			62	627.1	550.1	31.0	594.8	521.8	33.2	556.0	487.8	35.3
			57	568.9	568.9	30.7	536.6	536.6	32.9	530.0	530.0	35.1
WCPS 700B	700	18000	72	792.2	396.0	34.0	746.2	372.9	36.1	700.2	350.0	38.3
			67	742.7	503.2	33.6	700.0	474.5	35.8	657.8	445.6	38.1
			62	686.0	605.0	33.2	650.7	573.9	35.6	608.3	536.4	37.9
			57	622.4	622.4	32.9	587.0	587.0	35.3	581.0	581.0	37.6
WCPS 760B	760	20000	72	859.7	429.7	36.3	809.7	404.7	38.5	759.9	379.8	40.9
			67	806.0	546.0	35.9	760.0	514.9	38.2	713.8	483.6	40.7
			62	744.5	656.6	35.4	706.2	622.8	37.9	660.1	582.2	40.4
			57	675.5	675.5	35.1	637.0	637.0	37.7	630.0	630.0	40.1
WCPS 800B	800	22000	72	905.0	452.3	39.6	852.4	426.0	42.0	799.9	399.9	44.7
			67	848.4	574.8	39.2	800.0	542.0	41.8	751.4	509.1	44.4
			62	783.7	691.2	38.7	743.4	655.6	41.4	694.9	612.8	44.1
			57	711.1	711.1	38.4	670.6	670.6	41.1	665.0	665.0	43.8
WCPS 860B	860	24000	72	973.3	554.0	42.1	916.3	521.5	44.8	859.9	489.4	47.6
			67	912.1	678.8	41.9	860.0	668.6	44.4	807.8	627.9	47.4
			62	842.5	857.0	41.2	799.1	731.1	44.1	746.9	684.3	47.0
			57	764.3	864.4	40.9	721.0	815.4	43.8	715.1	808.7	46.7
WCPS 950B	950	26000	72	1075.3	546.8	45.5	1012.3	514.8	48.4	950.0	483.1	51.4
			67	1007.6	670.0	45.2	950.0	660.0	48.0	892.4	619.9	51.2
			62	930.8	846.0	44.6	882.8	721.7	47.6	825.2	705.0	50.8
			57	844.4	853.3	44.2	796.5	804.9	47.3	788.7	797.0	50.4
WCPS 1140B	1140	28000	72	1290.9	649.6	54.4	1215.3	611.6	57.8	1140.5	573.9	61.3
			67	1209.6	796.0	54.1	1140.0	784.1	57.4	1071.3	736.4	61.1
			62	1117.4	1005.0	53.2	1059.8	857.4	56.9	990.7	840.0	60.7
			57	1013.7	1013.7	52.8	956.2	956.2	56.5	950.0	950.0	60.2
WCPS 1340B	1340	32000	72	1516.9	763.3	65.7	1428.1	718.7	69.7	1340.2	674.4	74.0
			67	1421.4	935.3	65.2	1340.0	921.4	69.2	1258.9	865.4	73.7
			62	1313.1	1181.0	64.2	1245.4	1007.5	68.7	1164.1	997.0	73.2
			57	1191.2	1191.2	63.7	1123.6	1123.6	68.2	1110.0	1110.0	72.7
WCPS 1520B	1520	36000	72	1720.1	865.6	72.5	1619.4	814.9	77.0	1519.7	764.7	81.8
			67	1611.8	1060.6	72.1	1520.0	1044.8	76.5	1427.5	981.3	81.4
			62	1489.0	1339.2	71.0	1412.2	1142.5	75.9	1320.1	1104.0	80.9
			57	1350.8	1350.8	70.4	1274.2	1274.2	75.4	1204.0	1204.0	80.3

Notes: 1.) Ratings are gross capacities. For net capacities, deduct evaporator blower motor heat.
2.) At 80°F [26.6°C] DB air on evaporator.

3.) Compressor KW input.



SYSTEM COOLING CAPACITY

PERFORMANCE DATA

R407C

Model	Standard Capacity MBH	Air On Evap.		Water Temperature Off Condenser - °F								
		CFM	WB Temp. °F	80			95			110		
				Total MBH'	Sens MBH²	kW³	Total MBH'	Sens MBH²	KW³	Total MBH'	Sens MBH²	kW³
WCPS 68BP	66.0	2000	72	74.2	39.9	3.3	69.9	37.5	3.6	63.1	33.9	3.7
			67	70.8	53.0	3.2	66.0	49.4	3.5	62.5	46.8	3.7
			62	64.6	64.6	3.2	59.7	59.7	3.4	57.0	57.0	3.6
			57	57.0	57.0	3.2	52.8	52.8	3.4	50.1	50.1	3.6
WCPS 81BP	78.6	2400	72	88.4	43.4	3.9	83.2	40.6	4.2	72.3	38.5	4.3
			67	84.3	55.3	3.7	78.6	53.1	4.1	74.5	51.5	4.2
			62	76.9	66.4	3.7	71.1	64.0	4.0	67.9	62.2	4.2
			57	67.9	67.9	3.6	62.9	62.9	4.0	59.7	59.7	4.2
WCPS 95BP	92.1	2800	72	103.7	55.9	4.8	97.7	52.5	5.3	88.2	49.7	5.5
			67	98.8	74.3	4.6	92.1	69.4	5.2	87.4	65.7	5.4
			62	90.3	90.3	4.6	84.5	84.5	4.9	79.7	79.7	5.3
			57	79.8	79.8	4.5	73.8	73.8	4.9	70.0	70.0	5.3
WCPS108BP	106.3	3500	72	119.6	66.2	5.5	112.5	62.4	5.8	112.6	62.4	6.1
			67	114.0	88.1	5.3	106.3	82.2	5.8	100.7	77.9	6.1
			62	105.3	105.3	5.2	98.5	98.5	5.7	92.9	92.9	5.9
			57	92.9	92.9	5.2	86.1	86.1	5.6	81.6	81.6	5.9
WCPS125BP	121.3	3800	72	136.5	73.9	6.4	128.5	69.6	6.9	121.3	65.7	7.2
			67	130.1	97.6	6.1	121.3	90.9	6.7	114.8	86.1	7.0
			62	118.7	118.7	6.1	111.2	111.2	6.6	104.9	104.9	6.9
			57	104.9	104.9	6.0	97.3	97.3	6.6	92.1	92.1	6.9
WCPS 145BP	140.7	4000	72	158.3	75.4	7.3	149.1	71.0	7.8	140.7	66.9	8.2
			67	150.9	99.5	6.9	140.7	92.7	7.6	133.2	87.8	7.9
			62	137.7	121.2	6.9	128.9	113.5	7.5	121.6	108.0	7.8
			57	121.6	108.0	6.8	112.8	100.2	7.5	106.9	94.9	7.8
WCPS 160BP	155.2	4200	72	174.5	100.6	8.2	164.4	94.8	8.9	155.1	89.3	9.2
			67	166.5	136.3	8.0	155.2	127.0	8.7	147.1	120.4	9.1
			62	151.9	151.9	7.9	142.3	142.3	8.4	134.2	134.2	8.9
			57	134.2	134.2	7.6	124.1	124.1	8.4	118.0	118.0	8.9
WCPS 190BP	184.3	5800	72	207.3	82.8	9.5	195.4	105.1	10.2	184.3	99.1	10.5
			67	197.7	147.1	9.0	184.3	137.1	9.9	174.7	129.9	10.3
			62	180.4	178.9	9.0	168.9	167.6	9.6	159.4	159.4	10.2
			57	158.7	158.7	8.8	147.7	147.7	9.6	140.1	140.1	10.2
WCPS 220BP	213.4	6400	72	241.3	141.7	11.2	227.5	133.6	12.3	213.4	125.2	12.6
			67	226.4	189.0	10.7	213.4	178.2	11.8	200.4	167.3	12.4
			62	209.1	209.1	10.7	198.3	198.3	11.4	172.7	172.7	12.3
			57	189.7	189.7	10.5	168.2	168.2	11.4	164.9	164.9	12.3
WCPS 250BP	242.5	6800	72	272.8	145.5	12.8	257.0	137.0	13.9	242.4	129.3	14.2
			67	257.2	190.8	12.2	242.5	179.8	13.4	229.8	170.5	14.0
			62	237.3	225.6	12.2	221.5	221.5	13.0	209.7	209.7	13.9
			57	215.4	215.4	11.9	194.4	194.4	13.0	184.2	184.2	13.9
WCPS 290BP	279.4	7800	72	316.1	160.4	14.3	297.8	151.1	15.2	281.4	141.8	16.2
			67	296.4	205.8	14.2	279.4	194.0	15.0	262.5	182.3	16.1
			62	273.7	247.8	14.0	259.7	235.1	15.0	242.7	219.7	16.0
			57	248.4	248.4	13.9	234.3	234.3	14.8	217.3	217.3	15.9
WCPS 320BP	310.4	8400	72	351.2	177.2	16.4	330.9	166.9	17.7	310.5	156.7	18.2
			67	333.2	225.7	15.6	310.4	212.7	17.2	291.7	199.8	18.0
			62	304.0	270.3	15.6	288.6	256.1	16.7	269.8	239.7	17.7
			57	276.0	276.0	15.3	260.3	260.3	16.7	252.2	252.2	17.7
WCPS 380BP	368.6	10500	72	414.6	217.5	18.7	393.7	204.9	20.3	368.6	193.5	20.9
			67	395.5	286.7	17.8	368.6	267.1	19.7	349.4	253.3	20.6
			62	360.7	346.8	17.8	337.9	325.0	19.1	318.7	306.5	20.3
			57	318.7	318.7	17.5	308.9	308.9	19.1	298.8	298.8	20.3
WCPS 435BP	422.0	11500	72	456.4	232.1	22.1	429.9	218.5	23.6	403.3	205.0	24.9
			67	427.9	347.6	22.0	422.0	280.0	23.4	378.9	263.0	24.8
			62	395.2	359.3	21.6	374.8	340.6	23.3	350.4	318.4	24.6
			57	358.6	358.6	21.5	338.2	338.2	23.0	331.8	331.8	24.5

Notes: 1.) Ratings are gross capacities. For net capacities, deduct evaporator blower motor heat.
 2.) At 80°F [26.6°C] DB air on evaporator.
 3.) Compressor KW input.



SYSTEM COOLING CAPACITY

PERFORMANCE DATA

R407C

Model	Standard Capacity MBH	Air On Evap.		Water Temperature Off Condenser - °F								
		CFM	WB Temp. °F	80			95			110		
				Total MBH'	Sens MBH²	kW³	Total MBH'	Sens MBH²	KW³	Total MBH'	Sens MBH²	kW³
WCPS 480BP	465.6	13500	72	526.7	266.1	24.5	496.1	250.7	26.1	465.5	235.2	27.6
			67	493.7	337.7	24.3	465.6	318.6	25.9	437.3	299.3	27.5
			62	456.1	406.0	23.9	432.5	385.1	25.6	404.4	360.0	27.3
			57	413.8	413.8	23.7	390.3	390.3	25.4	384.1	384.1	27.1
WCPS 510BP	494.7	14500	72	559.7	282.7	25.8	527.2	266.4	27.3	494.7	249.9	28.9
			67	524.7	358.9	25.4	494.7	338.6	27.1	464.7	318.0	28.8
			62	484.7	431.5	25.1	459.7	409.2	26.9	429.7	382.5	28.6
			57	439.7	439.7	24.8	414.8	414.8	26.7	407.4	407.4	28.4
WCPS 570BP	552.9	15500	72	625.7	317.5	28.0	589.4	299.1	29.8	553.0	280.6	31.6
			67	586.6	406.1	27.8	552.9	389.5	29.6	519.4	359.8	31.5
			62	541.8	490.5	27.4	513.9	465.2	29.4	480.3	434.8	31.3
			57	491.6	491.6	27.2	463.7	463.7	29.1	455.9	455.9	31.0
WCPS 640BP	620.8	17000	72	702.3	353.2	32.7	661.5	332.7	34.6	620.8	312.4	36.9
			67	658.4	446.7	32.4	620.8	421.1	34.4	583.2	395.6	36.6
			62	608.3	539.1	31.9	577.0	511.4	34.2	539.3	478.0	36.4
			57	551.8	551.8	31.6	520.5	520.5	33.9	514.1	514.1	36.2
WCPS 700BP	679.0	18000	72	768.4	388.1	35.0	723.8	365.4	37.2	679.2	343.0	39.4
			67	720.4	493.1	34.6	679.0	465.0	36.9	638.1	436.7	39.2
			62	665.4	592.9	34.2	631.2	562.4	36.7	590.1	525.7	39.0
			57	563.6	563.6	33.9	569.4	569.4	36.4	563.6	563.6	38.7
WCPS 760BP	737.2	20000	72	833.9	421.1	37.4	785.4	396.6	39.7	737.1	372.2	42.1
			67	781.8	535.1	37.0	737.2	504.6	39.3	692.4	473.9	41.9
			62	722.2	643.5	36.5	685.0	610.3	39.0	640.3	570.6	41.6
			57	655.2	655.2	36.2	617.9	617.9	38.8	611.1	611.1	41.3
WCPS 800BP	776.0	22000	72	877.9	443.3	40.8	826.8	417.5	43.3	775.9	391.9	46.0
			67	822.9	563.3	40.4	776.0	531.2	43.1	728.9	498.9	45.7
			62	760.2	677.4	39.9	721.1	642.5	42.6	674.1	600.5	45.4
			57	689.8	689.8	39.6	650.5	650.5	42.3	645.1	645.1	45.1
WCPS 860BP	834.2	24000	72	944.1	542.9	43.4	888.8	511.1	46.1	834.1	479.6	49.0
			67	884.7	665.2	43.2	834.2	655.2	45.7	783.6	615.3	48.8
			62	817.2	817.2	42.4	775.1	716.5	45.4	724.5	670.6	48.4
			57	741.4	741.4	42.1	699.4	699.4	45.1	693.6	693.6	48.1
WCPS 950BP	921.5	26000	72	1043.0	535.9	46.9	981.9	504.5	49.9	921.5	473.4	52.9
			67	977.4	656.6	46.6	921.5	646.8	49.4	865.6	607.5	52.7
			62	902.9	829.1	45.9	856.3	707.3	49.0	800.4	690.9	52.3
			57	819.1	819.1	45.5	772.6	772.6	48.7	765.0	765.0	51.9
WCPS 1140BP	1105.8	28000	72	1252.2	636.6	56.0	1178.8	599.4	59.5	1106.3	562.4	63.1
			67	1173.3	780.1	55.7	1105.8	768.4	59.1	1039.2	721.7	62.9
			62	1083.9	984.9	54.8	1028.0	840.3	58.6	961.0	823.2	62.5
			57	983.3	983.3	54.4	927.5	927.5	58.2	921.5	921.5	62.0
WCPS 1340BP	1299.8	32000	72	1471.4	748.0	67.7	1385.3	704.3	71.8	1300.0	660.9	76.2
			67	1378.8	916.6	67.2	1299.8	903.0	71.3	1221.1	848.1	75.9
			62	1273.7	1157.4	66.1	1208.0	987.4	70.8	1129.2	977.1	75.4
			57	1155.5	1155.5	65.6	1089.9	1089.9	70.2	1076.7	1076.7	74.9
WCPS 1520BP	1474.4	36000	72	1668.5	848.3	74.7	1570.8	798.6	79.3	1474.1	749.4	84.3
			67	1563.4	1039.4	74.3	1474.4	1023.9	78.8	1384.7	961.7	83.8
			62	1444.3	1312.4	73.1	1370.1	1119.7	78.2	1280.5	1081.9	83.3
			57	1310.3	1310.3	72.5	1236.0	1236.0	77.7	1167.9	1167.9	82.7

Notes: 1.) Ratings are gross capacities. For net capacities, deduct evaporator blower motor heat.
 2.) At 80°F [26.6°C] DB air on evaporator.
 3.) Compressor KW input.

BLOWER PERFORMANCE

Available External Static Pressure - IWG - For Accessories And Duct System Static Resistance (Allowance Made For Wet Coil And Filters)

1.) Direct Drive - WCPS 68B to 95B

WCPS 68B		WCPS 81B		WCPS 95B	
DD 10/10		DD 12/12		DD 12/12	
CFM	ESP	CFM	ESP	CFM	ESP
1800	1.14	2200	0.64	2600	0.44
1900	1.06	2300	0.58	2700	0.40
2000	0.97	2400	0.54	2800	0.32
2100	0.93	2500	0.50	2900	0.26

2.) Belt Drive - WCPS 108B to 1520B

RPM	CFM										Fan Model
	ESP	BHP	ESP	BHP	ESP	BHP	ESP	BHP	ESP	BHP	
WCPS 108B											
	2600		2900		3200		3500		3800		12 / 12
800	0.53	0.82	0.46	0.95	0.41	1.11	0.33	1.27	0.23	1.45	
900	0.80	1.01	0.76	1.17	0.70	1.33	0.63	1.50	0.55	1.72	
1000	1.04	1.21	1.06	1.38	1.02	1.57	0.95	1.77	0.88	2.00	
1100	1.26	1.42	1.33	1.62	1.36	1.85	1.32	2.08	1.23	2.32	
WCPS 125B											
	3000		3300		3600		3900		4200		12 / 12
850	0.65	1.10	0.58	1.26	0.53	1.45	0.45	1.63	0.35	1.85	
950	0.96	1.33	0.89	1.50	0.84	1.70	0.78	1.93	0.70	2.16	
1050	1.27	1.57	1.24	1.78	1.18	2.00	1.13	2.24	1.06	2.51	
1150	1.54	1.84	1.58	2.08	1.56	2.32	1.50	2.59	1.43	2.87	
WCPS 145B											
	3100		3400		3700		4000		4300		12 / 12
900	0.70	1.26	0.64	1.45	0.56	1.65	0.47	1.85	0.35	2.08	
1000	1.03	1.51	0.96	1.70	0.88	1.92	0.80	2.16	0.71	2.41	
1100	1.34	1.77	1.32	2.00	1.24	2.24	1.16	2.49	1.08	2.77	
1200	1.62	2.05	1.66	2.30	1.64	2.60	1.55	2.87	1.47	3.16	
WCPS 160B											
	3300		3600		3900		4200		4500		12 / 12
900	0.87	1.38	0.83	1.57	0.77	1.77	0.71	2.01	0.63	2.24	
1000	1.20	1.63	1.16	1.85	1.11	2.08	1.05	2.32	1.01	2.59	
1100	1.55	1.93	1.52	2.16	1.47	2.41	1.42	2.68	1.38	2.97	
1200	1.87	2.22	1.90	2.49	1.86	2.77	1.81	3.07	1.78	3.38	
WCPS 190B											
	5000		5400		5800		6200		6600		15 / 15
800	0.82	2.17	0.78	2.47	0.72	2.73	0.45	3.08	0.02	3.50	
900	1.21	2.59	1.16	2.91	1.11	3.26	1.06	3.62	0.98	3.98	
1000	1.62	3.04	1.59	3.39	1.54	3.81	1.48	4.19	1.42	4.64	
1100	2.08	3.64	2.05	3.98	2.01	4.37	1.97	4.84	1.89	5.32	
WCPS 220B											
	5600		6000		6400		6800		7200		15 / 15
850	0.99	2.84	0.94	3.16	0.80	3.50	0.38	3.94	-	-	
900	1.18	3.07	1.14	3.44	1.09	3.79	0.94	4.18	0.48	4.69	
1000	1.62	3.60	1.56	3.99	1.52	4.41	1.47	4.86	1.42	5.29	
1100	2.08	4.17	2.05	4.61	1.99	5.07	1.94	5.56	1.90	6.10	
WCPS 250B											
	5600		6000		6400		6800		7200		15 / 15
850	1.02	2.84	0.97	3.16	0.83	3.50	0.43	3.94	-	-	
900	1.21	3.07	1.17	3.44	1.12	3.79	0.99	4.18	0.51	4.69	
1000	1.65	3.60	1.59	3.99	1.55	4.41	1.52	4.86	1.45	5.29	
1100	2.11	4.17	2.08	4.61	2.02	5.07	1.99	5.56	1.93	6.10	
WCPS 290B											
	6200		6800		7400		8000		8600		18 / 13
800	1.55	3.60	1.44	4.10	1.33	4.64	1.23	5.15	0.84	5.78	
900	2.12	4.40	2.08	5.00	1.97	5.56	1.83	6.26	1.72	6.86	
1000	2.76	5.25	2.71	5.92	2.67	6.69	2.55	7.33	2.41	8.16	
1100	3.42	6.15	3.41	6.97	3.35	7.76	3.30	8.67	3.21	9.49	
WCPS 320B											
	6600		7200		7800		8400		8800		18 / 13
850	1.81	4.34	1.69	4.89	1.58	5.51	1.48	6.06	1.32	6.51	
900	2.12	4.81	2.04	5.36	1.90	6.02	1.77	6.66	1.72	7.09	
1000	2.74	5.68	2.70	6.43	2.62	7.10	2.48	7.87	2.39	8.46	
1100	3.43	6.69	3.39	7.49	3.35	8.38	3.27	9.23	3.19	9.77	
WCPS 380B											
	7600		8400		9200		10000		10800		18 / 18
700	0.86	3.52	0.75	4.11	0.53	4.77	0.21	5.45	-	-	
750	1.10	3.89	1.00	4.54	0.87	5.24	0.61	6.00	0.26	6.81	
800	1.36	4.33	1.27	4.98	1.15	5.76	1.00	6.55	0.69	7.45	
850	1.63	4.77	1.55	5.48	1.44	6.27	1.31	7.14	1.10	8.05	

Note: Data shown for Class 1 fan construction.

BLOWER PERFORMANCE

RPM	CFM										Fan Model
	ESP	BHP	ESP	BHP	ESP	BHP	ESP	BHP	ESP	BHP	
WCPS 435B											
	8600		9400		10200		11000		11800		18 / 18
700	0.77	4.26	0.55	4.94	0.22	5.67	-	-	-	-	
750	1.04	4.73	0.92	5.43	0.59	6.19	0.29	7.04	0.05	7.97	
800	1.31	5.17	1.21	5.94	1.01	6.77	0.70	7.66	0.37	8.64	
850	1.59	5.67	1.50	6.49	1.36	7.38	1.14	8.32	-	-	
WCPS 480B											
	8000		9500		11000		12500		14000		500
550	0.68	2.64	0.56	3.34	0.39	4.17	0.19	5.11	-	-	
650	1.16	3.54	1.07	4.38	0.93	5.36	0.77	6.49	0.53	7.69	
750	1.68	4.64	1.63	5.64	1.51	6.75	1.38	8.03	1.19	9.50	
850	2.21	5.98	2.24	7.09	2.16	8.42	2.05	9.86	1.89	11.50	
WCPS 510B											
	10000		11500		13000		14500		16000		560
500	0.66	3.34	0.57	4.03	0.42	4.79	0.24	5.67	0.03	6.62	
600	1.22	4.64	1.15	5.46	1.03	6.41	0.89	4.78	0.68	8.59	
700	1.79	6.29	1.80	7.21	1.73	8.33	1.59	9.58	1.42	10.92	
800	2.42	8.35	2.44	9.41	2.45	10.66	2.38	12.16	2.24	13.74	
WCPS 570B											
	11000		13500		15000		15800		16500		560
550	0.85	4.48	0.62	5.90	0.45	6.89	0.32	7.41	0.23	7.91	
650	1.45	6.01	1.29	7.73	1.13	8.86	1.03	9.58	0.95	10.17	
700	1.75	6.92	1.64	8.77	1.49	10.00	1.39	10.75	1.32	11.35	
800	2.40	9.03	2.39	11.17	2.31	12.57	2.22	13.55	2.16	14.30	
WCPS 640B											
	14600		15400		16200		17000		17800		560
550	0.65	6.61	0.52	7.10	0.44	7.75	0.37	8.32	0.22	8.96	
650	1.32	8.58	1.22	9.18	1.13	9.89	1.08	10.61	0.94	11.90	
700	1.69	9.66	1.58	10.39	1.51	11.08	1.46	11.91	1.33	12.65	
750	2.08	10.94	1.98	11.67	1.91	12.46	1.87	13.33	1.75	14.15	
WCPS 700B											
	15600		16400		17200		18000		18800		560
550	0.55	7.26	0.45	7.88	0.33	8.47	0.24	9.12	0.10	9.80	
600	0.89	8.27	0.79	8.95	0.67	9.57	0.60	10.34	0.46	11.05	
650	1.25	9.39	1.15	10.06	1.05	10.81	0.75	11.55	0.83	12.36	
700	1.63	10.64	1.53	11.23	1.45	12.71	1.37	12.93	1.25	13.88	
WCPS 760B											
	13000		15000		17000		19000		21000		630
500	0.95	5.50	0.83	6.54	0.77	7.87	0.37	9.44	-	-	
550	1.29	6.59	1.18	7.72	1.06	9.11	0.87	10.68	0.48	12.64	
600	1.64	7.74	1.55	9.09	1.44	10.56	1.27	12.15	1.06	14.20	
650	1.94	8.99	1.94	10.55	1.84	12.15	1.69	13.92	1.52	15.95	
WCPS 800B											
	15000		17000		19000		21000		23000		630
550	1.33	7.72	1.22	9.12	1.10	10.70	0.75	12.64	0.12	14.75	
600	1.70	9.09	1.59	10.52	1.50	12.20	1.33	14.20	0.91	16.50	
640	2.01	10.25	1.92	11.82	1.82	13.50	1.70	15.63	1.46	18.00	
680	2.33	11.40	2.26	13.21	2.16	15.03	2.05	17.14	1.89	19.62	
WCPS 860B											
	17000		19000		21000		23000		25000		710
400	0.69	5.88	0.59	6.86	0.47	8.08	0.19	9.40	-	-	
450	1.05	7.18	0.98	8.31	0.87	9.55	0.72	10.98	0.52	12.64	
500	1.42	8.58	1.39	9.96	1.29	11.28	1.16	12.86	1.03	14.58	
600	2.22	12.17	2.23	13.61	2.20	15.42	2.11	17.30	2.02	19.32	
WCPS 950B											
	19000		21000		23000		25000		27000		710
450	0.95	8.31	0.85	9.56	0.70	10.98	0.48	12.63	-	-	
500	1.35	9.92	1.27	11.29	1.14	12.86	1.00	14.59	0.81	16.47	
600	2.20	13.62	2.18	15.43	2.09	17.30	1.99	19.32	1.84	21.53	
650	2.66	15.94	2.66	17.66	2.60	19.87	2.52	22.11	2.39	24.46	
WCPS 1140B											
	20000		22000		24000		26000		28000		2 x 560
500	0.60	6.71	0.55	7.58	0.45	8.55	0.36	9.69	0.26	10.83	
600	1.12	9.19	1.10	10.33	1.02	11.58	0.93	12.81	0.86	14.26	
700	1.65	12.35	1.69	13.71	1.64	15.06	1.59	16.70	1.52	18.37	
800	2.24	16.25	2.29	17.86	2.29	19.47	2.27	21.13	2.25	23.13	
WCPS 1340B											
	25000		27000		29000		31000		33000		2 x 560
500	0.40	9.13	0.30	10.22	0.20	11.40	0.07	12.77	-	-	
600	0.96	12.15	0.90	13.57	0.80	14.94	0.67	16.52	0.55	18.17	
700	1.61	15.88	1.55	17.51	1.47	19.19	1.37	21.06	1.25	22.86	
800	2.28	20.33	2.27	22.19	2.22	24.16	2.12	26.29	2.03	28.54	
WCPS 1520B											
	28000		30000		32000		34000		36000		2 x 560
500	0.25	10.83	0.13	12.09	-	-	-	-	-	-	
600	0.85	14.26	0.74	15.80	0.60	17.34	0.49	19.08	0.35	20.89	
700	1.51	18.37	1.41	20.10	1.31	22.00	1.20	23.99	1.07	26.16	
800	2.24	23.13	2.16	25.19	2.06	27.36	1.96	29.60	1.87	32.15	

Note: Data shown for Class 1 fan construction.

DIMENSIONAL DATA

WCPS 68B, 81B, 95B

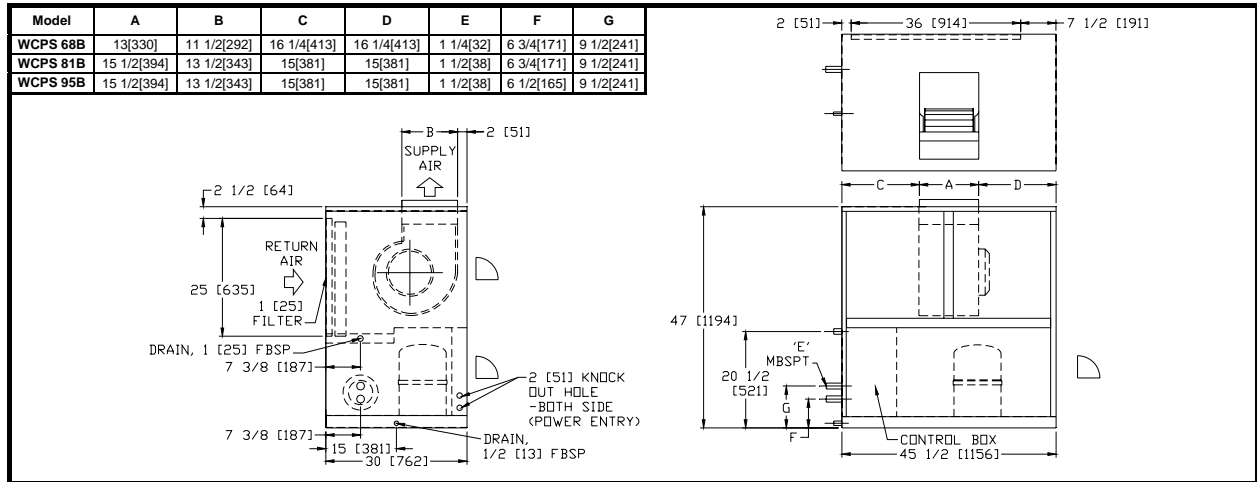

WCPS 108B, 125B, 145B, 160B

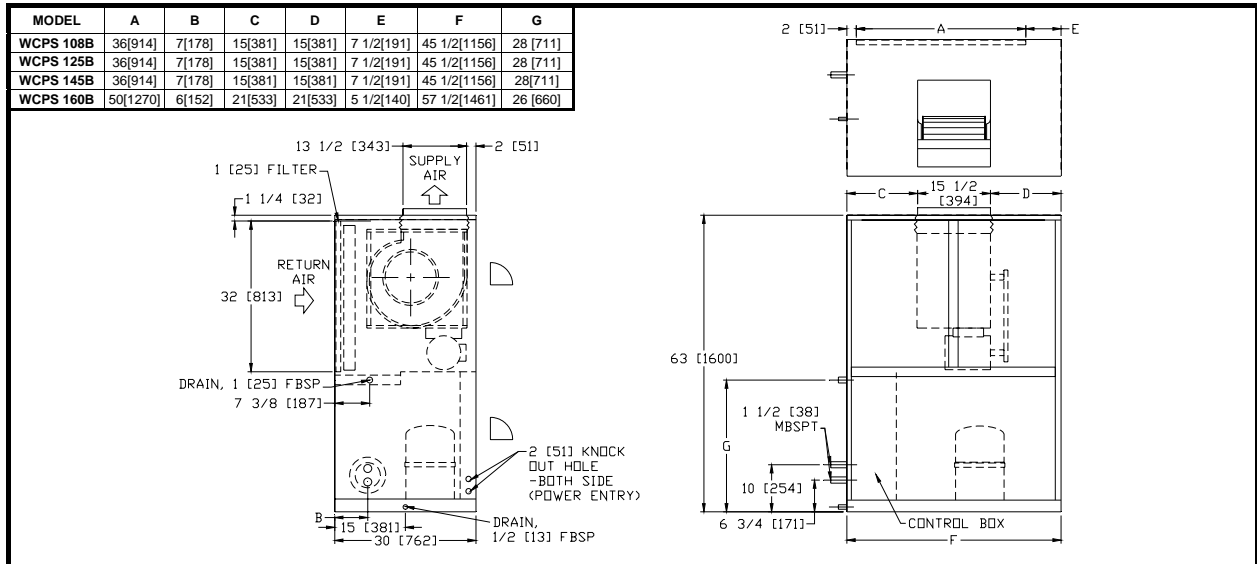

WCPS 190B

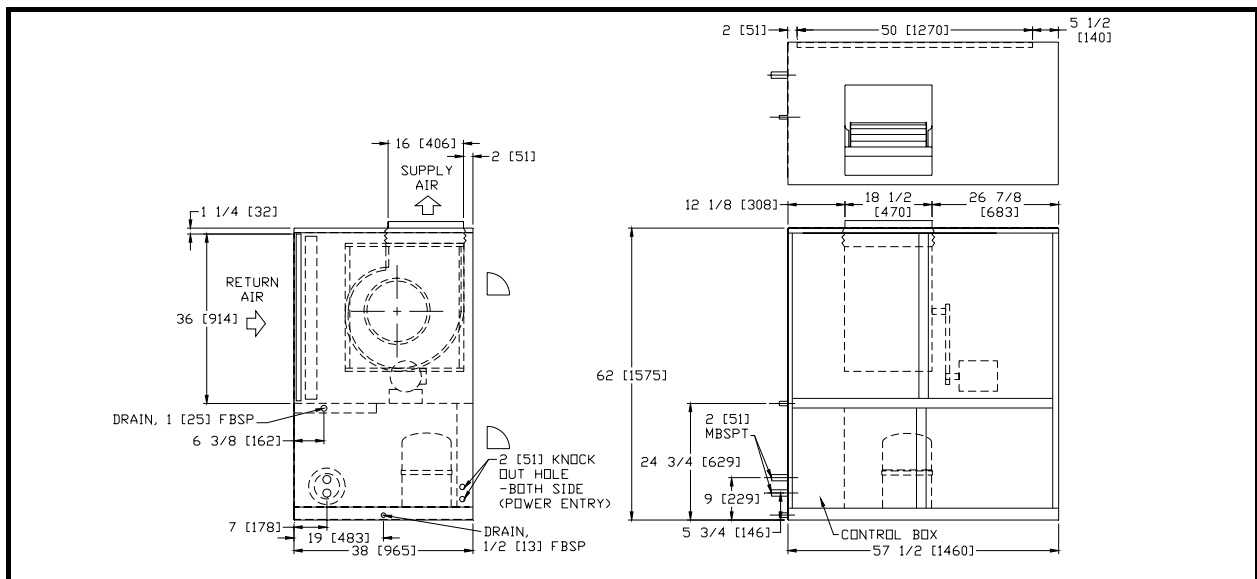

Note: All dimensions are in inches[mm].

DIMENSIONAL DATA

WCPS 220B, 250B

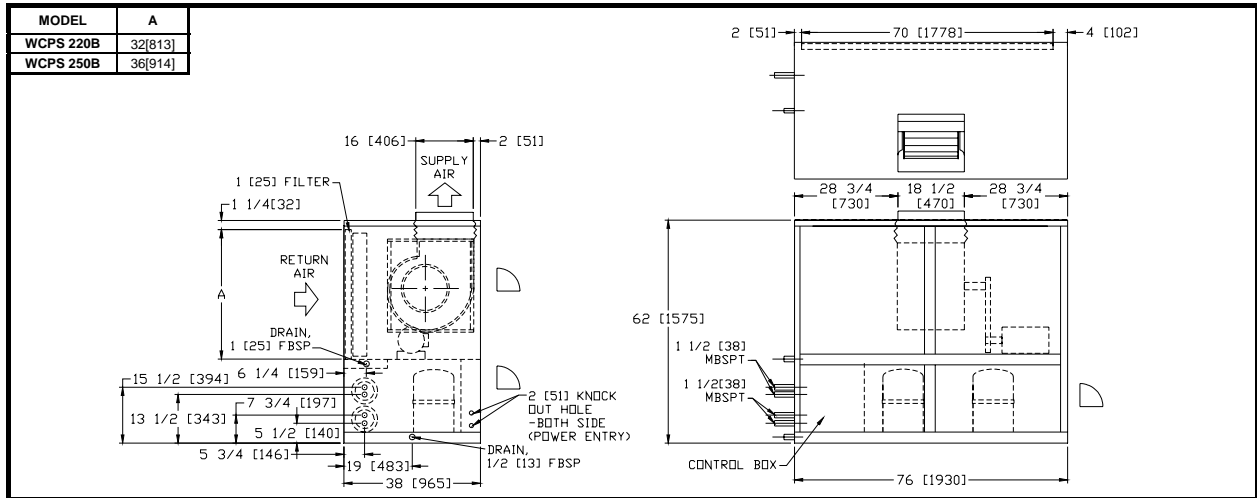

WCPS 290B, 320B, 380B

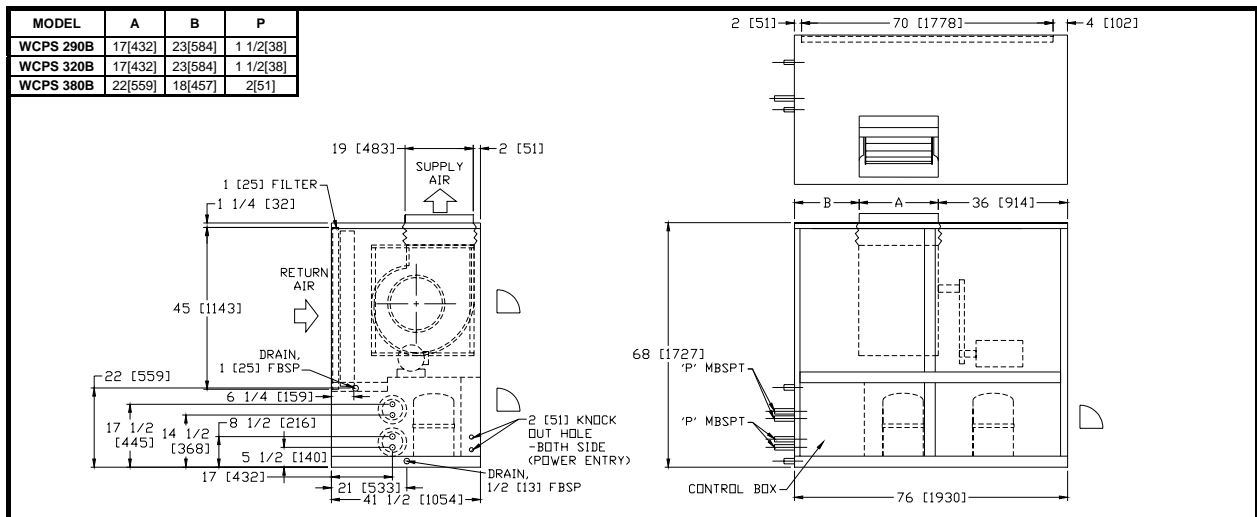

WCPS 435B

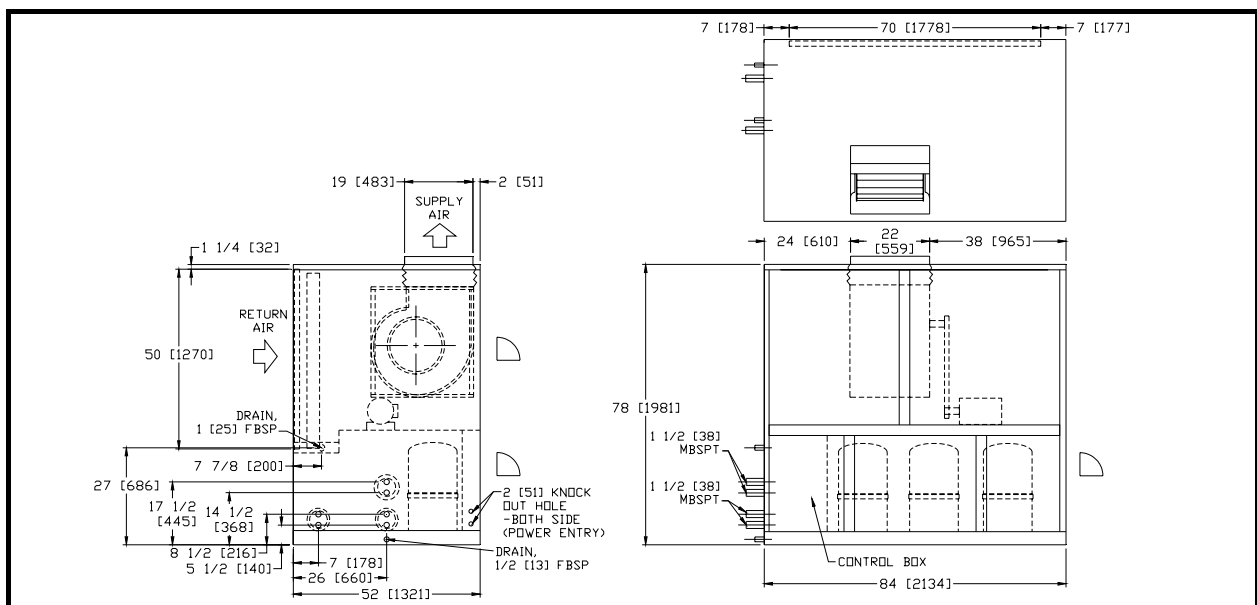

Note: All dimensions are in inches[mm].

DIMENSIONAL DATA

WCPS 480B, 510B, 570B

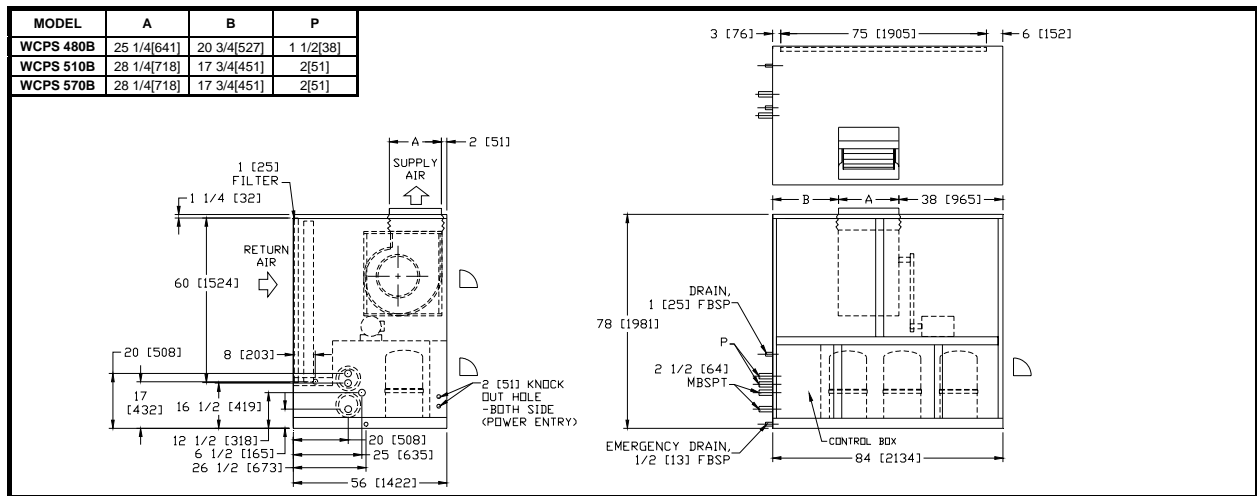

WCPS 640B, 700B, 760B

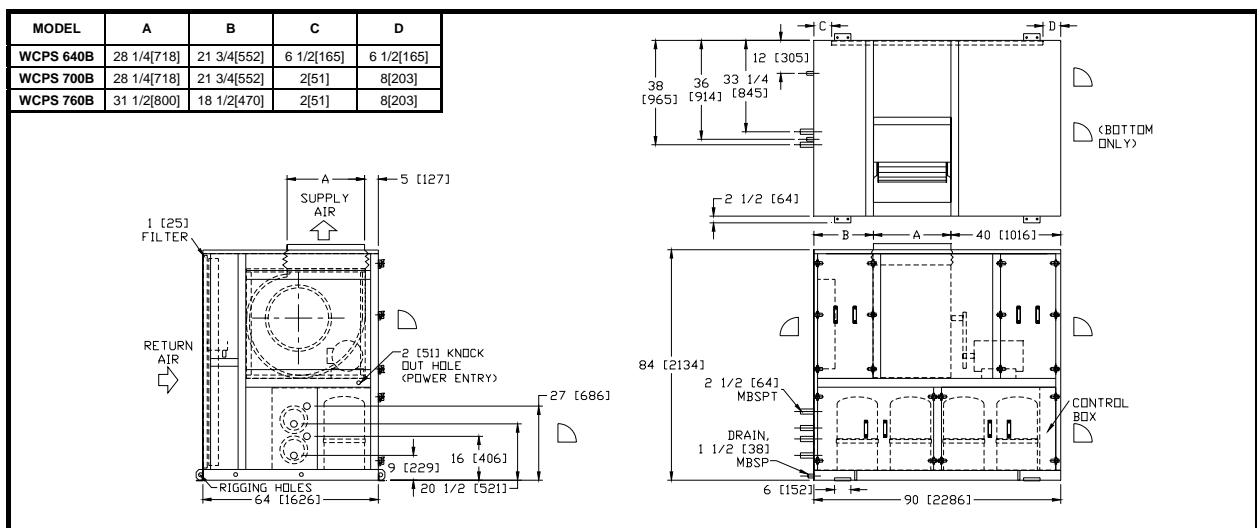

WCPS 800B, 860B, 950B

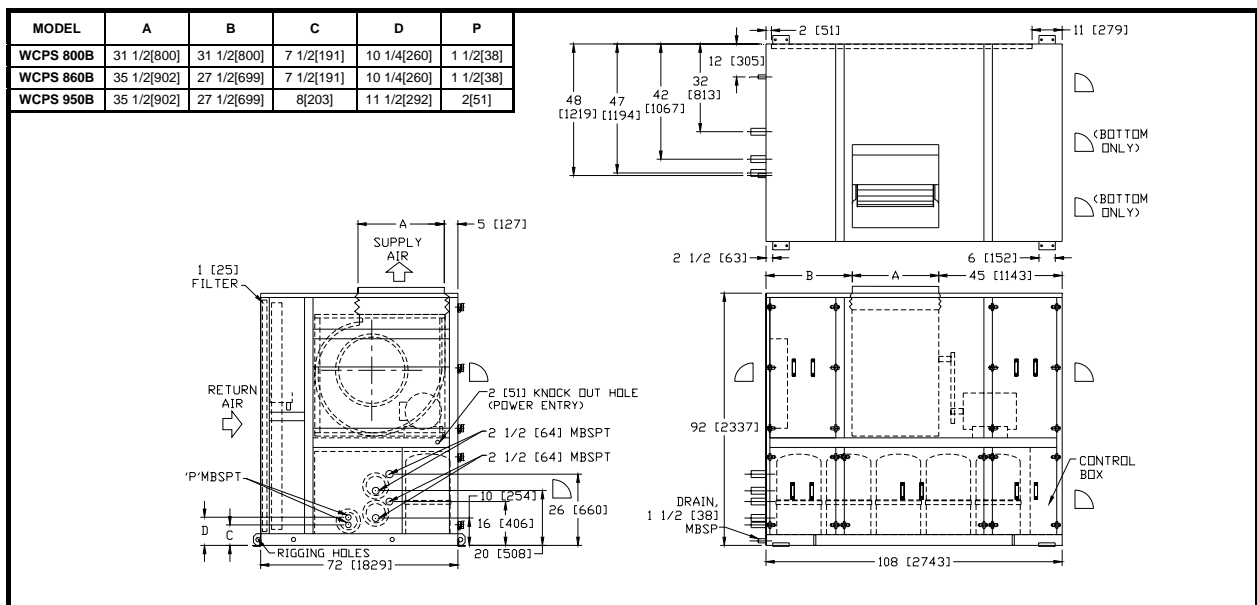

Note: All dimensions are in inches[mm].

DIMENSIONAL DATA

WCPS 1140B, 1340B, 1520B

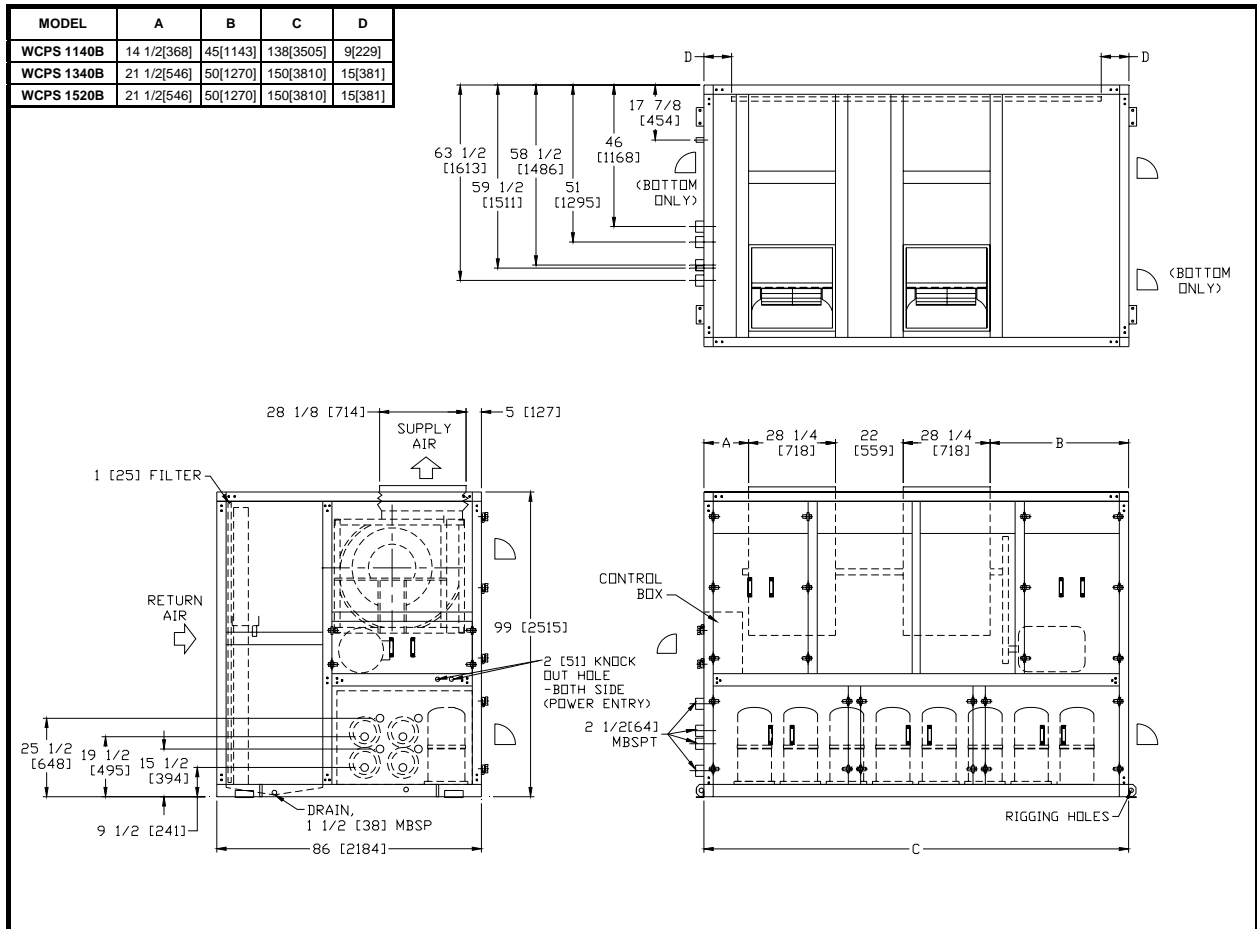

FLOOR STANDING FREE - BLOW TYPE

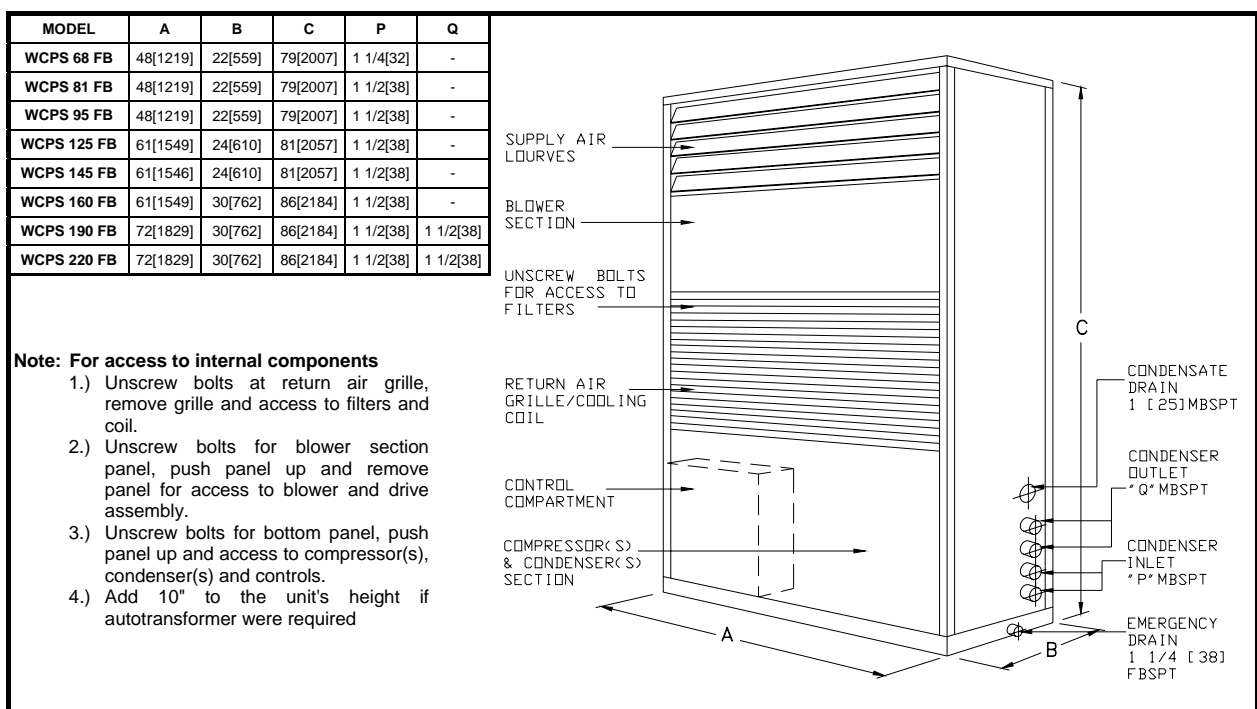

Note: All dimensions are in inches[mm].

ELECTRICAL

TYPICAL WIRING DIAGRAM

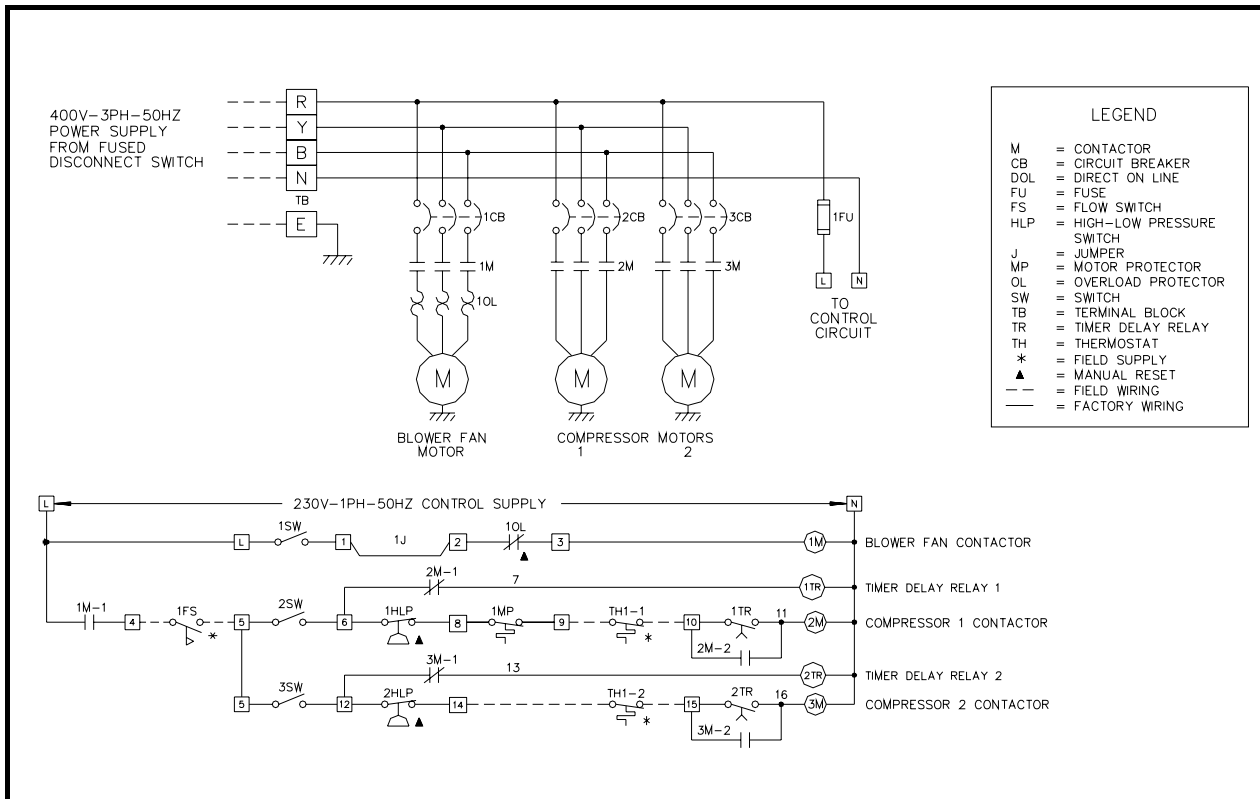

CORRECTION FACTORS

To correct for variation in air flow, use this multiplier.

AIR FLOW VARIATION	TOTAL CAPACITY	SENSIBLE CAPACITY
0.8	0.960	0.900
0.9	0.980	0.950
1.0	1.000	1.000
1.1	1.015	1.045
1.2	1.025	1.090

To correct for altitude, use this multiplier.

ALTITUDE ABOVE SEA LEVEL - FT	TOTAL CAPACITY	SENSIBLE CAPACITY
0	1.00	1.00
2000	0.99	0.93
3000	0.98	0.91
4000	0.97	0.88
5000	0.96	0.85
6000	0.95	0.82
7000	0.94	0.80

To correct sensible capacity for varying dry bulb.

DRY BULB	WET BULB			
	57	62	67	72
75	0.84	0.81	0.78	0.74
80	1.00	1.00	1.00	1.00
85	1.16	1.18	1.21	1.26

Note: If the capacity after multiplying the sensible with the correction factor exceed the total capacity, then the sensible must be equal to the total.



Malaysia

Lot 5755-6, Kidamai Industrial Park,
Bukit Angkat,
43000 Kajang,
Selangor Darul Ehsan,
Malaysia

Tel: +603-8924 9000
Fax: +603-8739 5020

China

No. 1 Dunham-Bush Road,
Laishan District,
Yantai,
Shandong Province,
China 264003

Tel: +86-535-658 8999
Fax: +86-535-658 1999

United Kingdom

8 Downley Road,
Havant,
Hampshire,
England PO9 2JD

Tel: +44-23-9247 7700
Fax: +44-23-9245 0396

United Arab Emirates

Office # 2606,
Fortune Executive Towers,
Cluster T1, Jumeirah Lake Tower
Dubai, UAE

Tel: +971-4-443 9207
Fax: +971-4-443 9208

South Africa

No. 57 Sovereign Drive
Route 21 Corporate Park
Irene, Pretoria
South Africa

Tel: +27-12-345 4202
Fax: +27-12-345 4203

Singapore

2 Kallang Pudding Road
#07-07 Mactech Building
Singapore 349307

Tel: +65-6842 2012
Fax: +65-6842 2013

Vietnam

10th Floor, Nam A Bank Tower,
201-203 Cach Mang Thang 8 Street,
District 3, Ho Chi Minh City,
Vietnam

Tel: +84-8-6290 3108
Fax: +84-8-6290 3109

Indonesia

APL Tower, Central Park Podomoro City
19th Floor T2, T3, T5
Jl. Let. Jend. S. Parman Kav. 28
Jakarta Barat 11470, Indonesia

Tel: +62-21-3000 5829
Fax: +62-21-2903 4332



Please Scan Here

for quick link to Dunham-Bush website

DUNHAM-BUSH

info@dunham-bush.com
www.dunham-bush.com

Products that perform...By people who care

Manufacturer reserves the right to change specifications without prior notice.

M-S-0214J-0414