

DUNHAM-BUSH

Products that perform...By people who care

Form No: MM0208E

INSTALLATION, OPERATION & MAINTENANCE MANUAL

**MODEL:
ACPSB-P**

R-22/ R407C

**Air- Cooled
Single Package
Air Conditioner
With Scroll
Compressor**

- **Cooling**
- **Heat Pump**

1.0 INTRODUCTION

This equipment is factory manufactured air-cooled package for the purpose of cooling only or cooling and heating. It consists mainly of a direct expansion evaporator coil(s) with factory package thermal expansion valve, fully sealed rotary compressor (ACPRB 30P) or scroll compressor(s) (ACPSB 40P- 1520P) and large heat rejection condenser coil. Factory standard units also incorporate important safety and operating controls which includes manual reset high and low pressure cutout, compressor motor protectors, sight glass and liquid line filter drier for each compressor(s).

The air-cooled package consists of multiple compressors (except ACPRB 30P to ACPSB 190P) each with its own independent refrigerant circuit, which guarantee standby partial capacity in case of failure of any one compressor.

Every Dunham-Bush air-cooled single package air-conditioner has been carefully and intelligently designed, manufactured and tested. It is also subject to stringent quality control and accurately tested as a final verification of reliability. If it is correctly installed, operated and maintained, it will provide many years of satisfactory and efficient performance.

Note: For 60Hz, the smallest model is ACPSB 40P.

These instructions are general in nature and are for standard units only. Non-standard units may vary in some respects from these instructions to suit particular applications.

TABLE OF CONTENTS

DESCRIPTION	PAGE NO.
1.0 INTRODUCTION	2
2.0 GENERAL INFORMATION	
2.1 SAMPLE NOMENCLATURE	3
2.2 RECEIVING, INSPECTION AND PACKAGING	3
2.3 RIGGING AND UNCRATING	4
2.4 LIMITATIONS	4
2.5 PHYSICAL DIMENSION	5
3.0 INSTALLATION	
3.1 FOUNDATION.....	10
3.2 LOCATION	10
3.3 CLEARANCE	11
3.4 DUCT CONNECTIONS	12
3.5 DRAIN CONNECTION	12
4.0 OPERATION	
4.1 TYPICAL OPERATING SEQUENCE	13
4.2a TYPICAL WIRING SCHEMATIC – COOLING ONLY	14
4.2b TYPICAL WIRING SCHEMATIC – HEAT PUMP	15
4.3 PHASE ROTATION.....	16
4.4 CYCLE LIMIT RATE.....	16
4.5 FAN CYCLING (HEAT PUMP).....	16
4.6 DEFROST CYCLE (HEAT PUMP).....	16
4.7 CRANKCASE HEATER (HEAT PUMP).....	16
4.8 STOP VALVE	16
4.9 HYDROPHILIC CONDENSER COIL (STANDARD FOR HEAT PUMP).....	16
4.10 STAINLESS STEEL BOLTS AND NUTS.....	16
5.0 MAINTENANCE	
5.1 MAINTENANCE	17
5.2 TIGHTENING OF PULLEY SET SCREW.....	18
5.3 PULLEY ALIGNMENT.....	18
5.4 BELT TENSION INSPECTION GUIDE.....	19
5.5 LEAK TEST (SYSTEM PRESSURE TEST).....	20
5.6 VACUUM TEST AND DEHYDRATION	20
5.7 REPLACE OF DRIER OR SIGHT GLASS.....	21
5.8 CHARGING	21
5.9 LUBRICATION	21
5.10 TROUBLE-SHOOTING CHART	22
5.11 SAMPLE LOG SHEET	24
5.12 DUNHAM-BUSH STARTUP REPORT	25
5.13 STARTUP CHECK LIST	27
5.14 OPERATING PARAMETERS	28

2.0 GENERAL INFORMATION

2.1 SAMPLE NOMENCLATURE

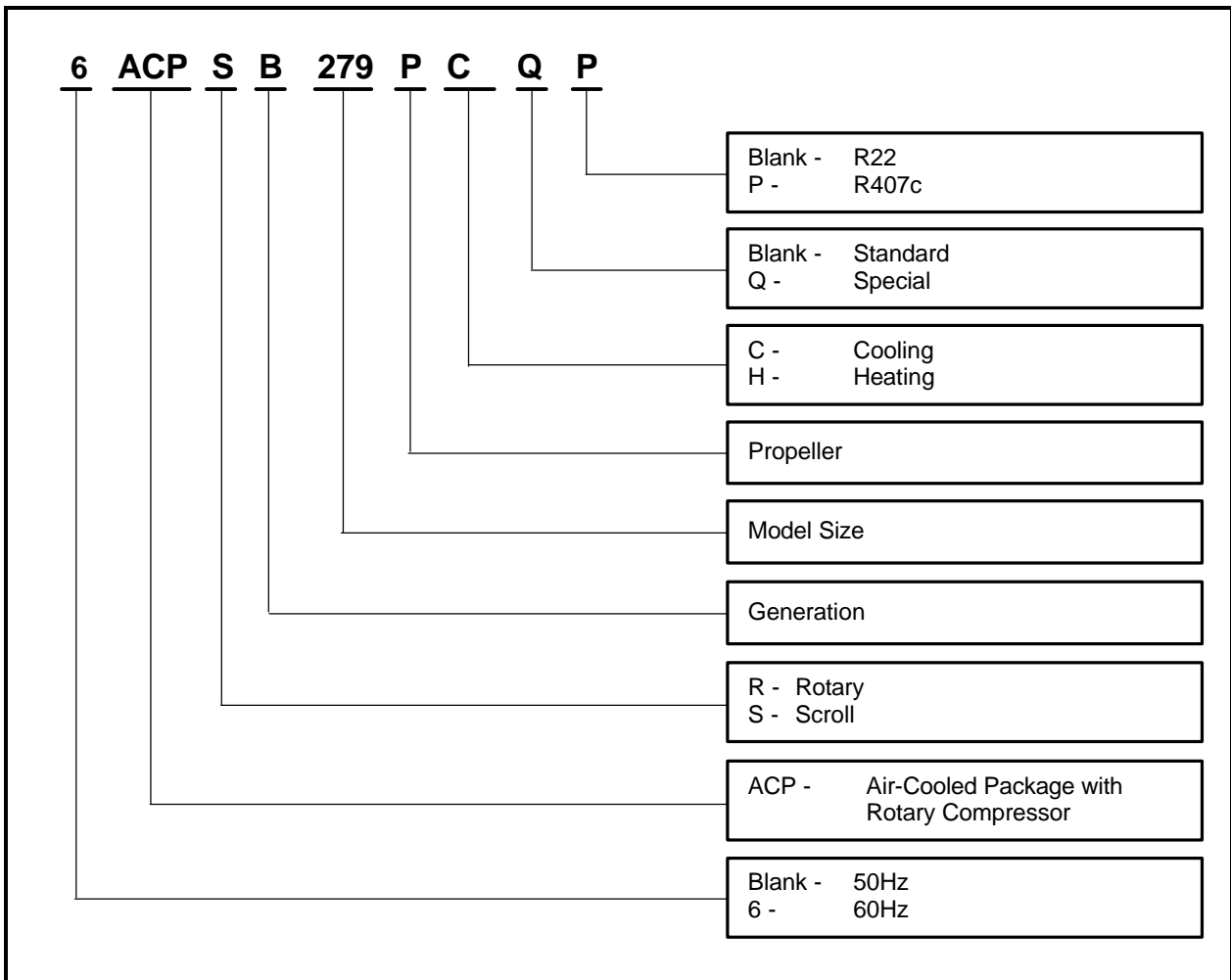

2.2 RECEIVING, INSPECTION AND PACKAGING

As soon as the unit is received, it should be inspected for any damage during transit. If damaged on the carrier's delivery, make a separate written request for inspection by the carrier's agent at once.

Whenever possible, immediately or at the earliest convenience, the unit should be inspected for any missing or short-shipped items and accessories. Any short-shipped items should be brought to the attention of the nearest Dunham-Bush representatives.

The standard units includes the following parts:

- 1.) Compressor(s) complete with rubber grommet (4 for each compressor).
- 2.) Condenser coil (hydrophilic fins complete with thermal expansion valve for heat pump).
- 3.) Evaporator coil complete with thermal expansion valve(s).
- 4.) Manual reset high and low pressure cut-out for each compressor.
- 5.) Sight glass and liquid line filter drier for each compressor.
- 6.) Blowers and relevant supports (motor mounting plate, bearings and shaft).
- 7.) Flexible canvas connections for blower outlets.
- 8.) Propeller fan(s), motor(s) and fan cover(s).

2.0 GENERAL INFORMATION

- 9.) Crankcase heater for compressors (heat pump only).
- 10.) Reversing valve, check valve and head pressure controller (heat pump only).
- 11.) Suction accumulator (heat pump only).

Other optional accessories includes:

- 1.) Motor, drive package and filters.
- 2.) Thermostat.
- 3.) Hot water heating coils or electric reheaters.
- 4.) Compressor time delay relay.
- 5.) Factory wired starter board.
- 6.) Copper and hydrophilic fins (hydrophilic fin is standard on heat pump condenser coil).
- 7.) Pressure gauges.
- 8.) Head pressure controller (Standard on heat pumps).
- 9.) Suction accumulator (Standard on heat pumps).
- 10.) Hot gas by pass.
- 11.) Liquid, suction and discharge stop valves.

2.3 RIGGING AND UNCRATING

Each unit has been tested, inspected and properly packed or crated prior to delivery. It is very important that same precautions are taken in handling the units by the installers, movers and riggers. Lift the units with a forklift. When lifting with slings, use spreader bars across the top of the unit to prevent any damage to the frame and panels. Rigging should be done in a manner to avoid any severe strain or stress on the unit which will scratch the paint work, damage the panels and framework. Avoid possible surface damage by not removing the packaging material until the unit is at or near the final location and soon to be installed. Check the weight of the unit before rigging. Place the rigging cable such that the weight is evenly distributed.

2.4 LIMITATIONS

- 1.) Avoid low return air temperature on evaporator coil which might cause condensate to freeze up the surface of the evaporator coil.
- 2.) Limit evaporator coil face velocity to 600 fpm [3.06 m/s] to avoid moisture carry over and excessive noise.
- 3.) Unit must be operated on the correct electrical supply as specified on unit name plate. Voltage limitation for compressor(s) and fan motor must be observed.
- 4.) Low ambient air temperature on the condensing coil might cause low discharge pressure (not necessary for units with head pressure control. Observe low ambient operation limitation.

2.0 GENERAL INFORMATION

2.5 PHYSICAL DIMENSION

ACPRB 30P, ACPSB 40P

MODEL	A	B
ACPRB 30P	32 [813]	16 [406]
ACPSB 40P	40 [1016]	20 [508]

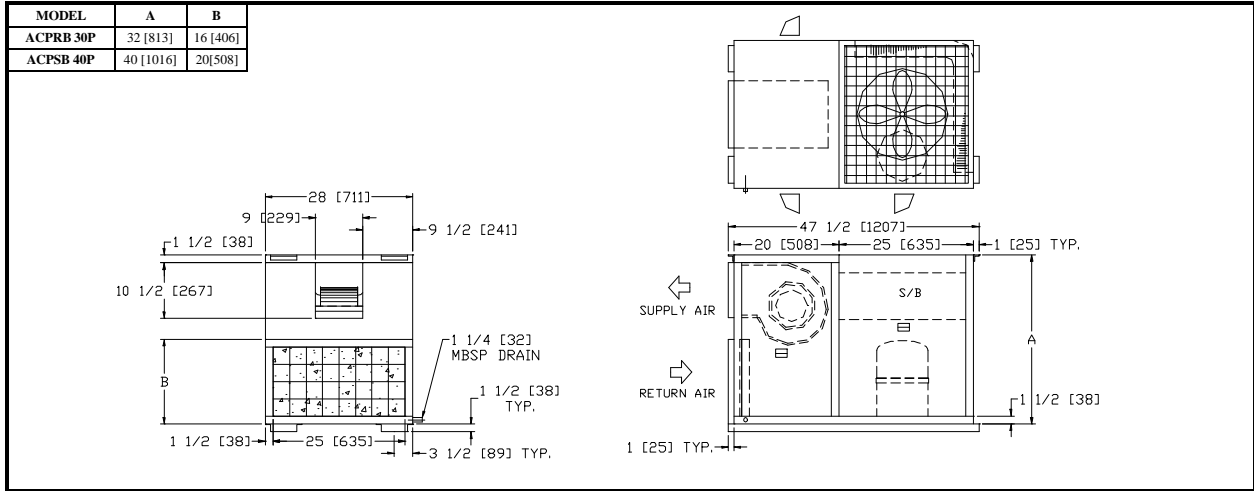

ACPSB 50P

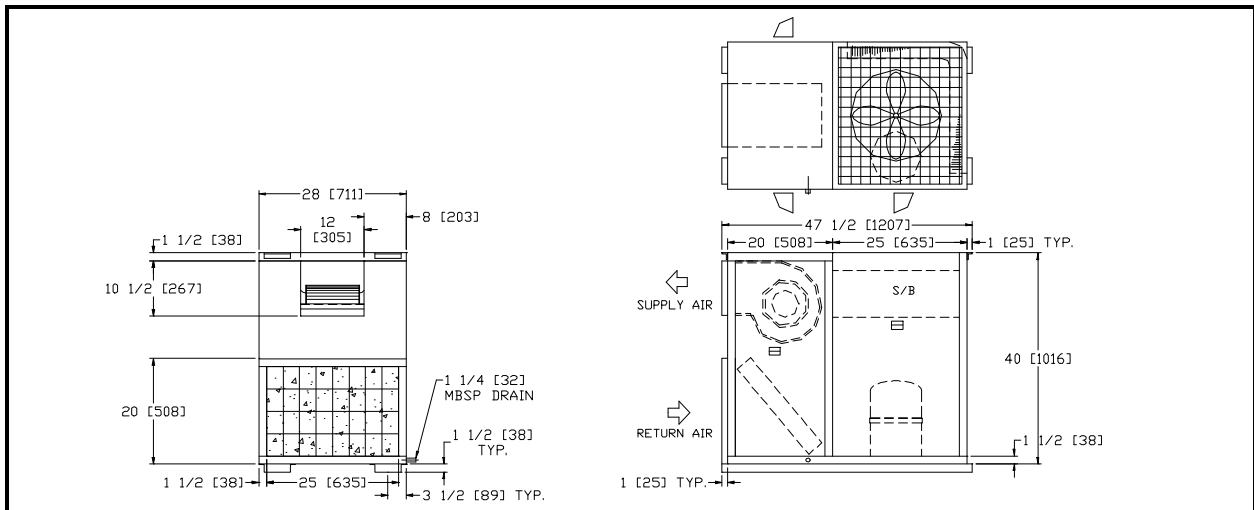

ACPSB 68P

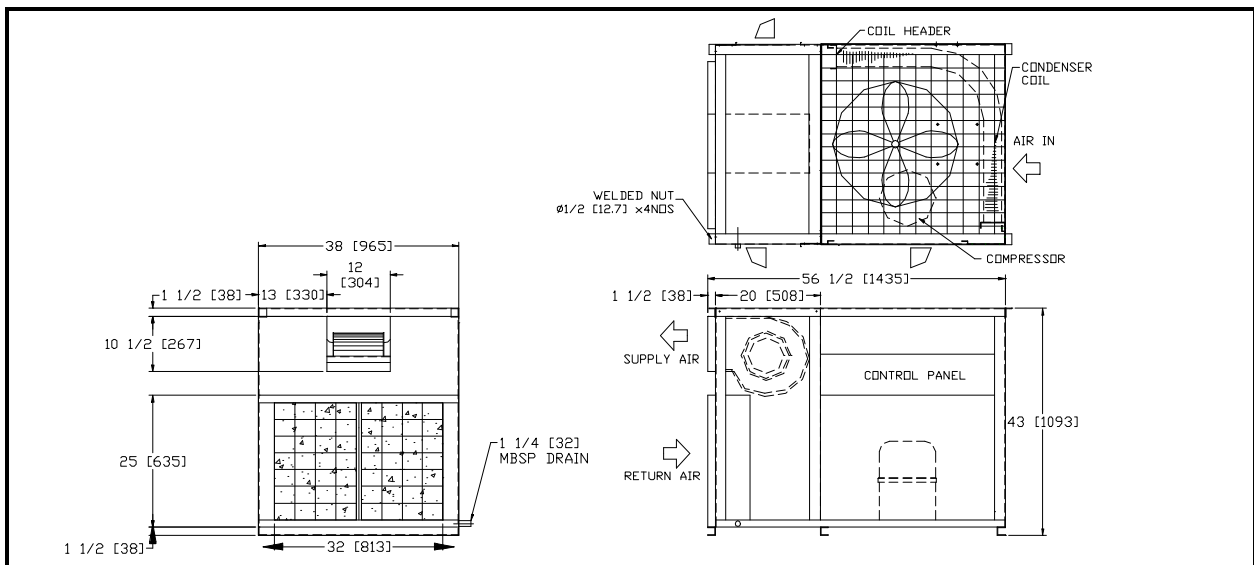

NOTE: ALL DIMENSIONS ARE IN INCHES [MM].

2.0 GENERAL INFORMATION

ACPSB 81P, 95P

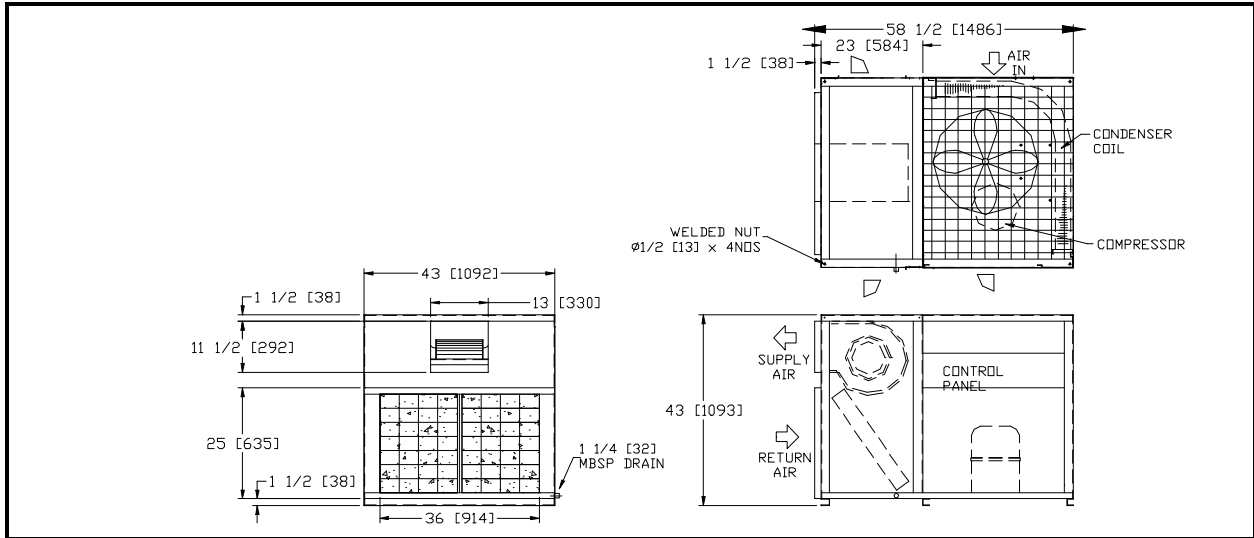

ACPSB 108P, 125P

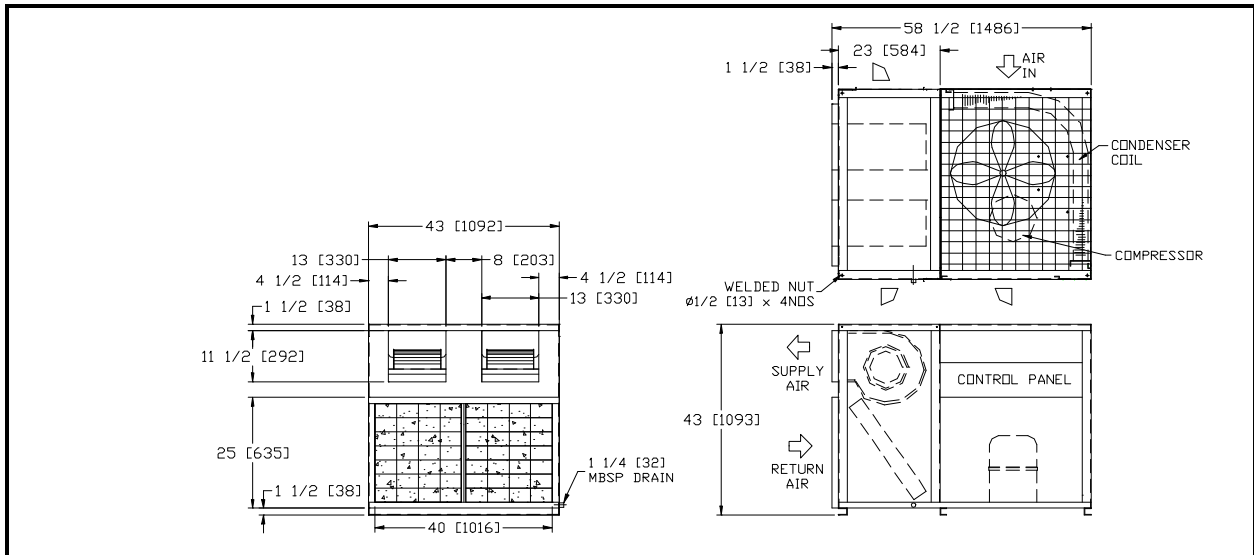

ACPSB 145P

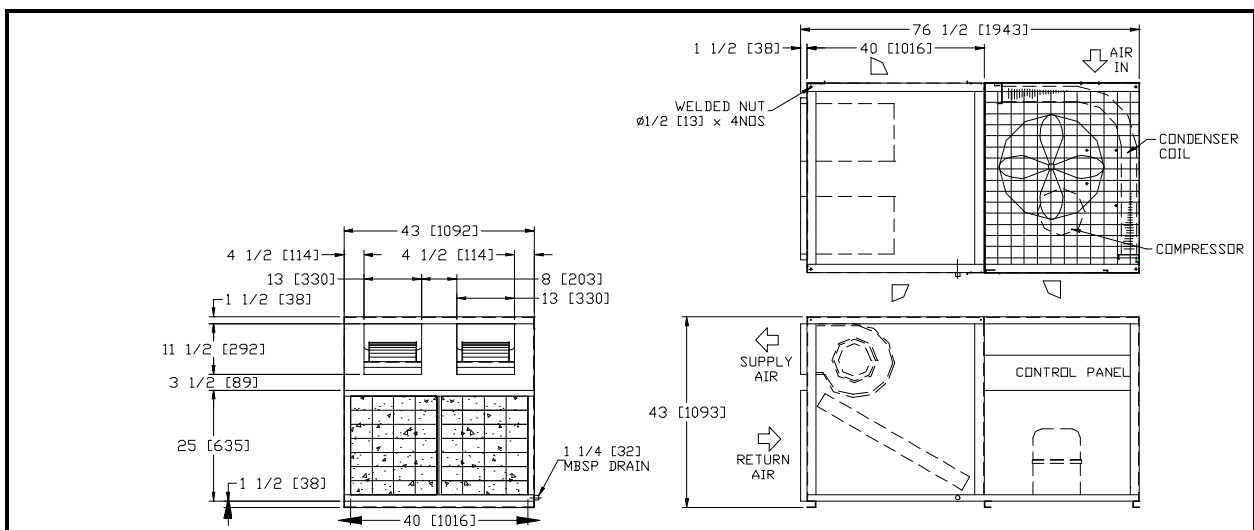

NOTE: ALL DIMENSIONS ARE IN INCHES[MM].

2.0 GENERAL INFORMATION

ACPSB 160P, 190P, 220P

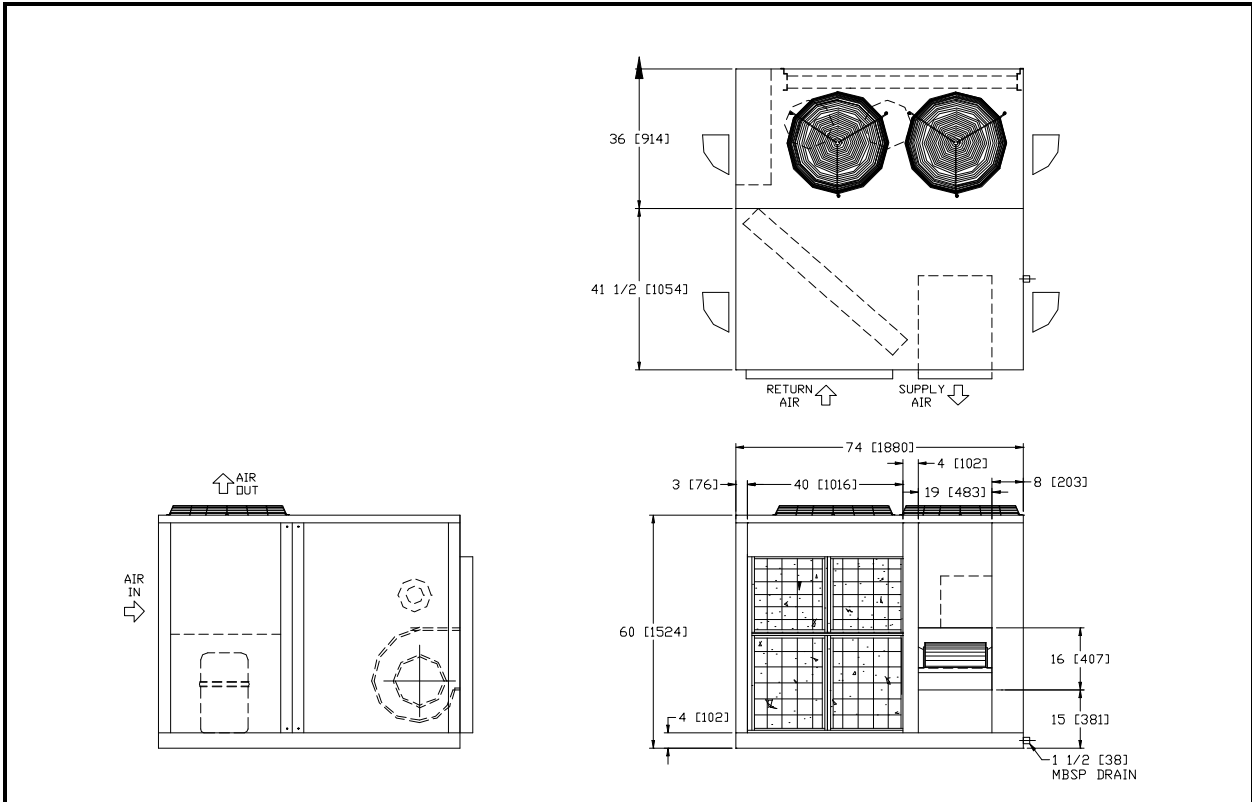

ACPSB 250P, 290P

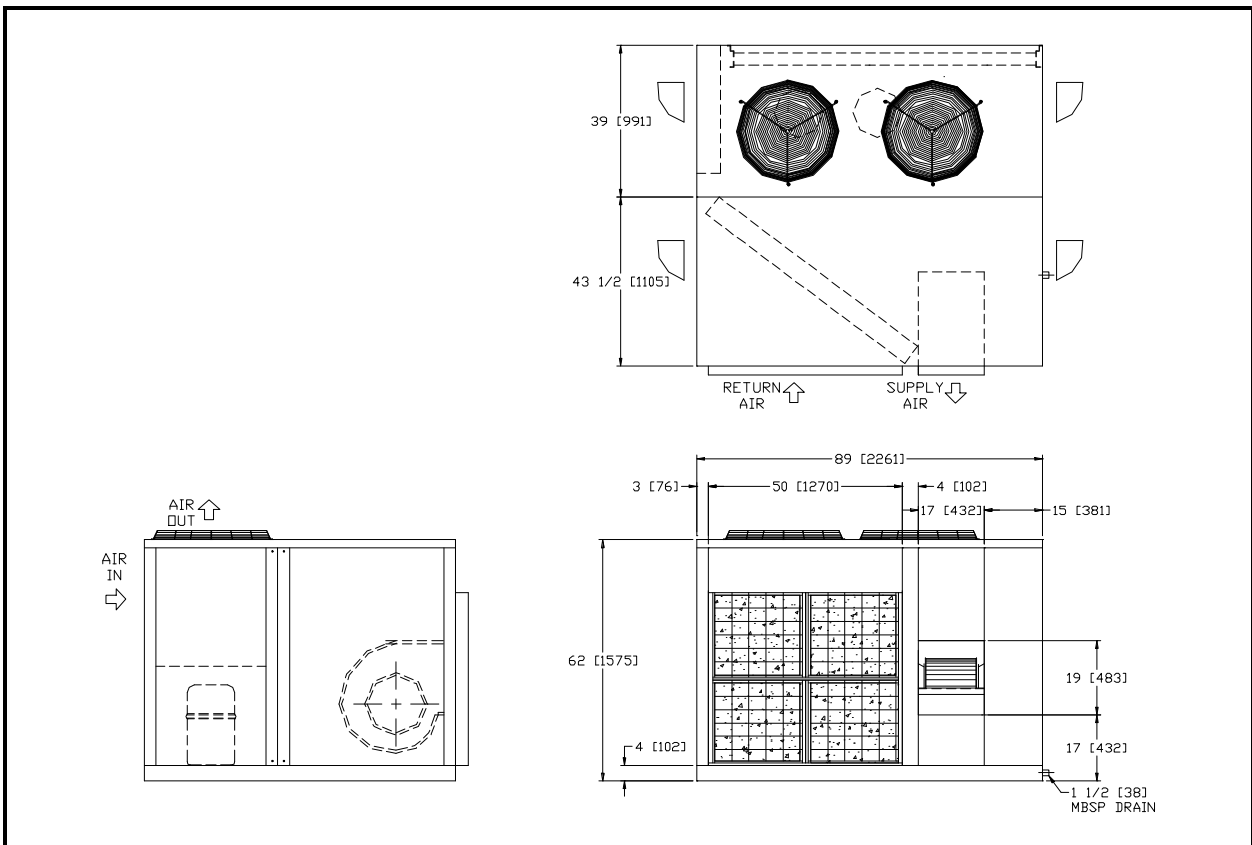

NOTE: ALL DIMENSIONS ARE IN INCHES[MM].

2.0 GENERAL INFORMATION

ACPSB 320P, 380P, 435P

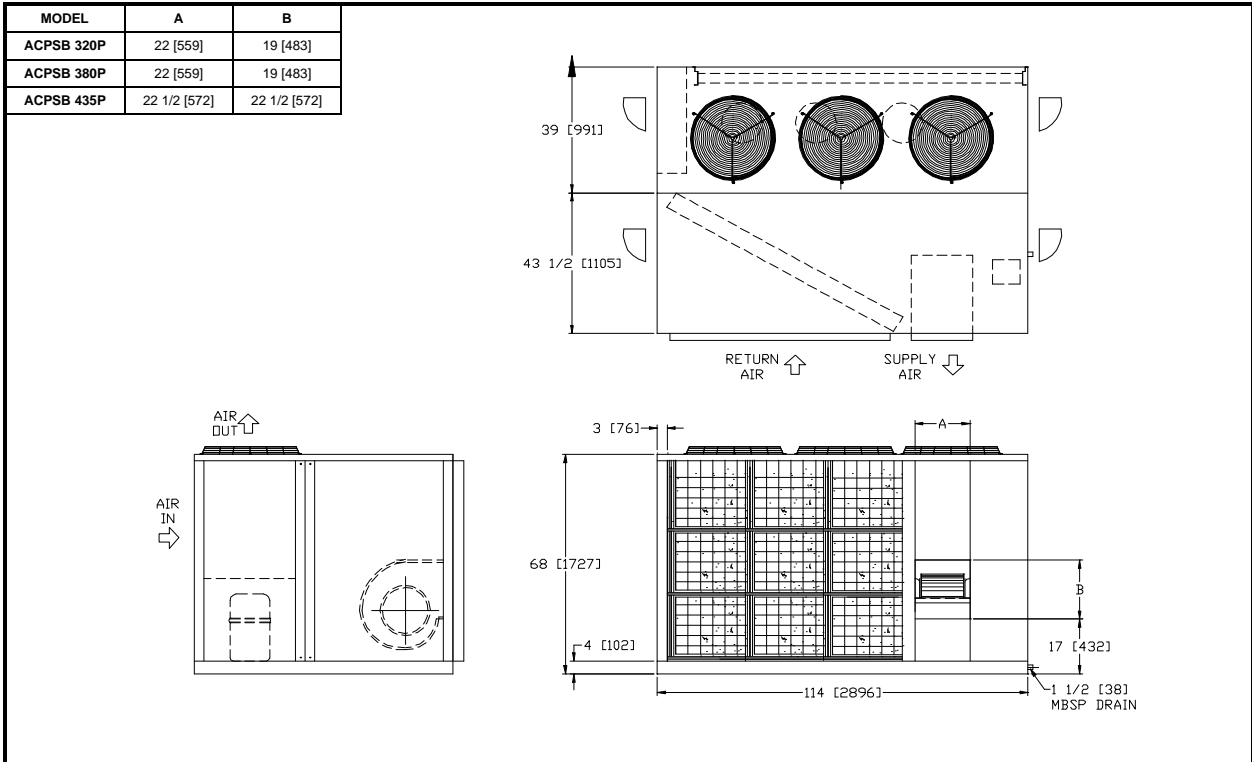

ACPSB 480P, 510P, 570P

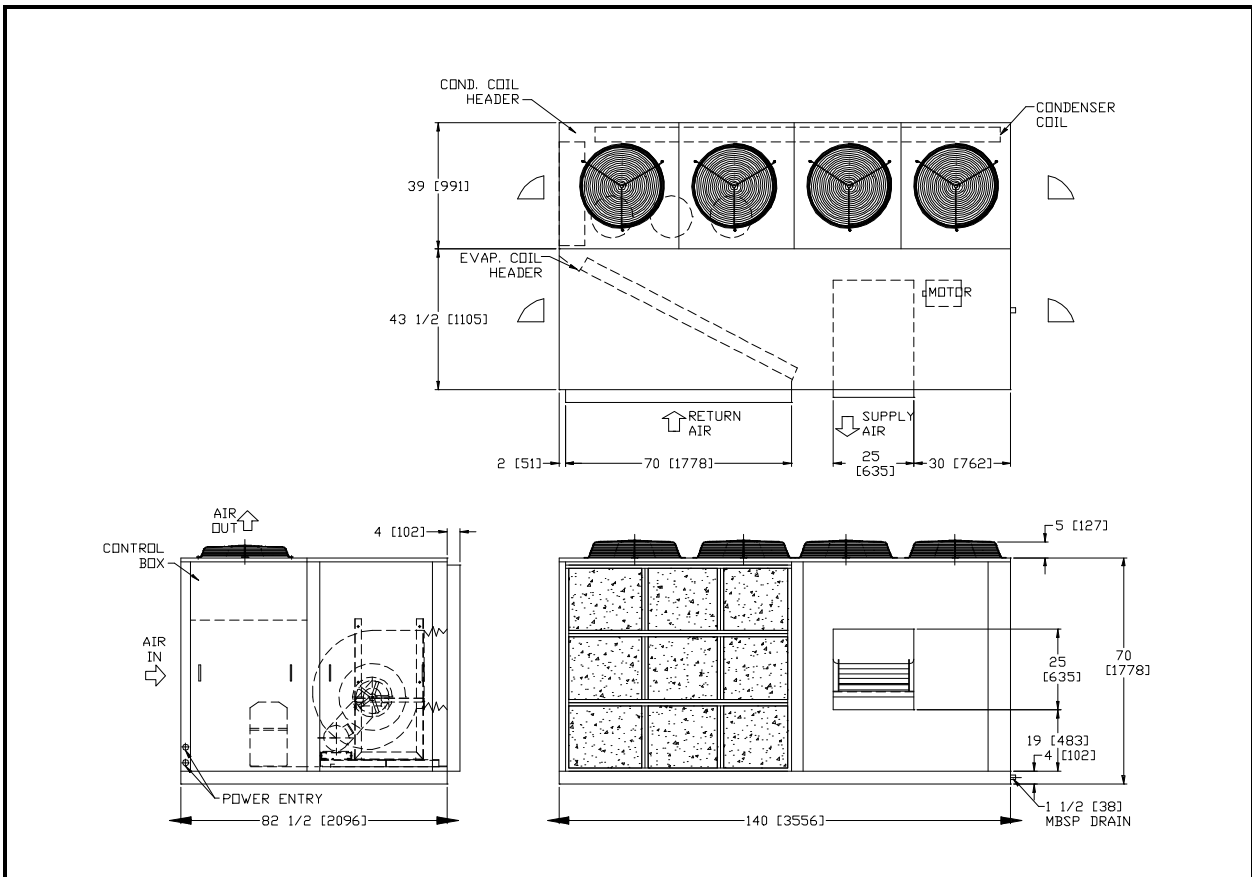

NOTE: ALL DIMENSIONS ARE IN INCHES[MM].

2.0 GENERAL INFORMATION

ACPSB 640P, 700P, 760P

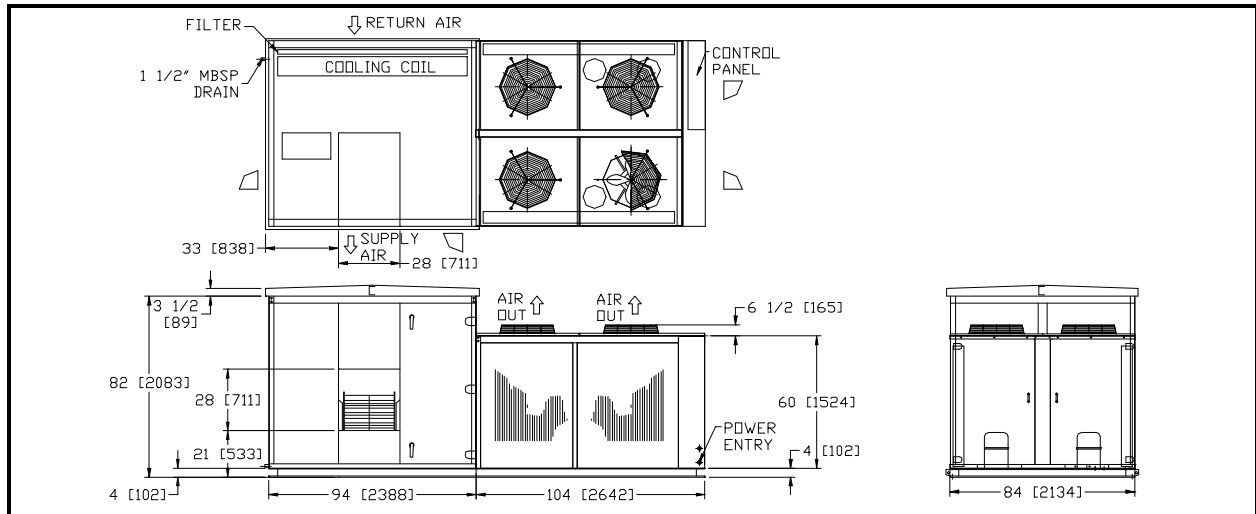

ACPSB 800P, 890P, 960P

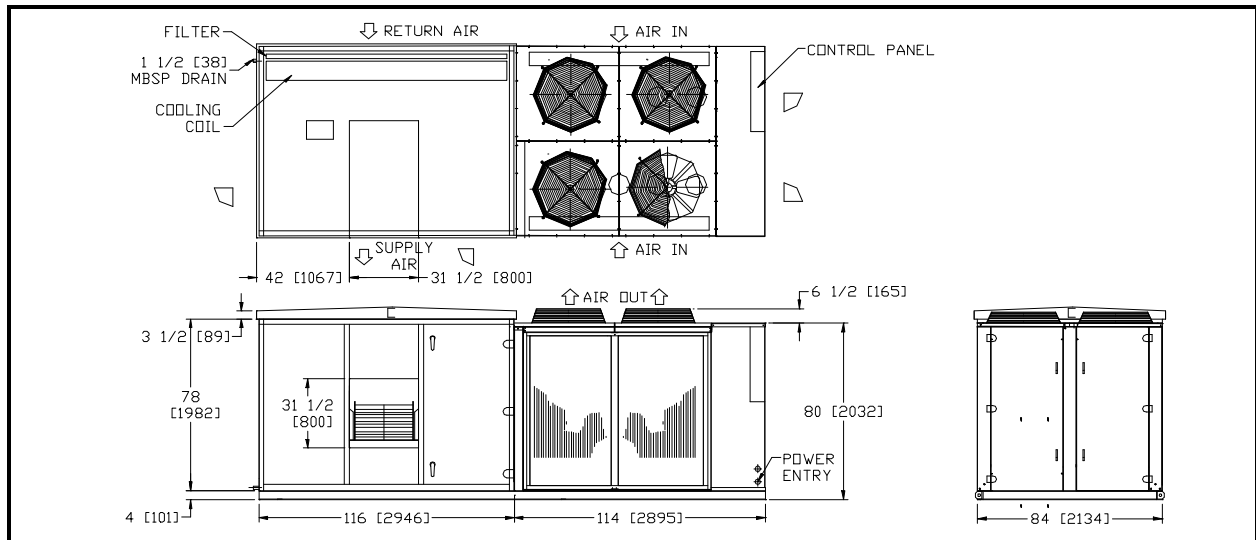

ACPSB 1020P, 1140P, 1340P, 1520P

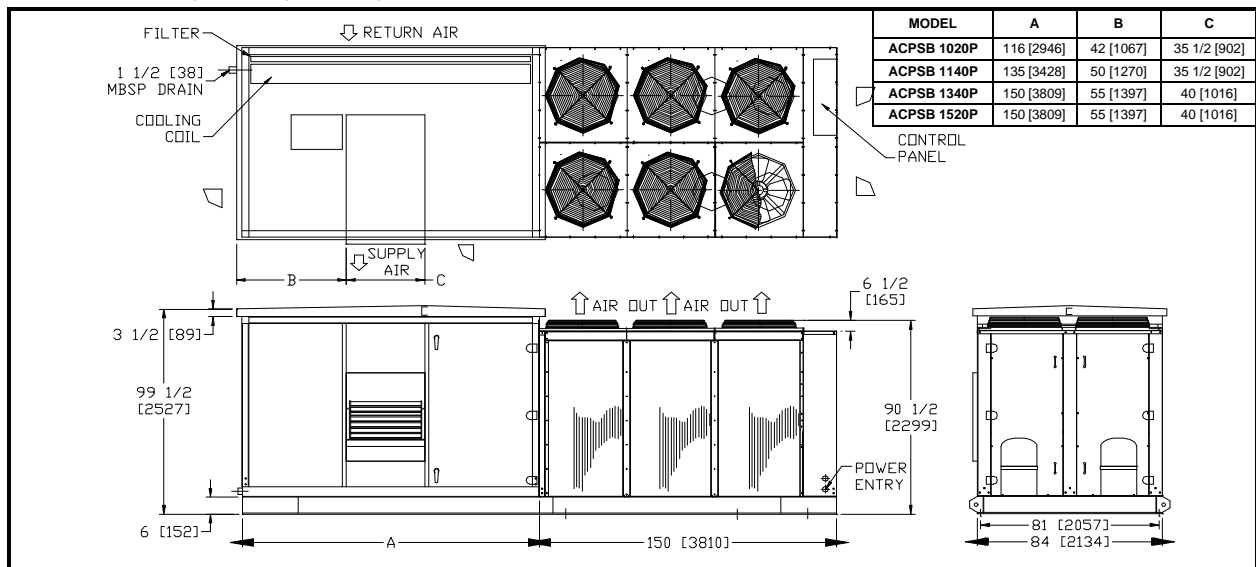

NOTE: ALL DIMENSIONS ARE IN INCHES[MM].

3.0 INSTALLATION

3.1 FOUNDATION

The unit shall be placed on a flat, level, solid foundation (plinth) or floor capable of supporting the weight of the unit. No special foundation or vibration isolator is generally required as the vibration transmitted from the unit's casing will not adversely affect the surrounding.

In extreme cases where it is necessary to completely isolate any vibration from the air-conditioner or when any vibration from the unit can adversely affect any other nearby equipment, it is recommended that either one of the following methods be followed:

FIGURE 3.1(a): PROVIDE A SEPARATE FLOATING PLINTH

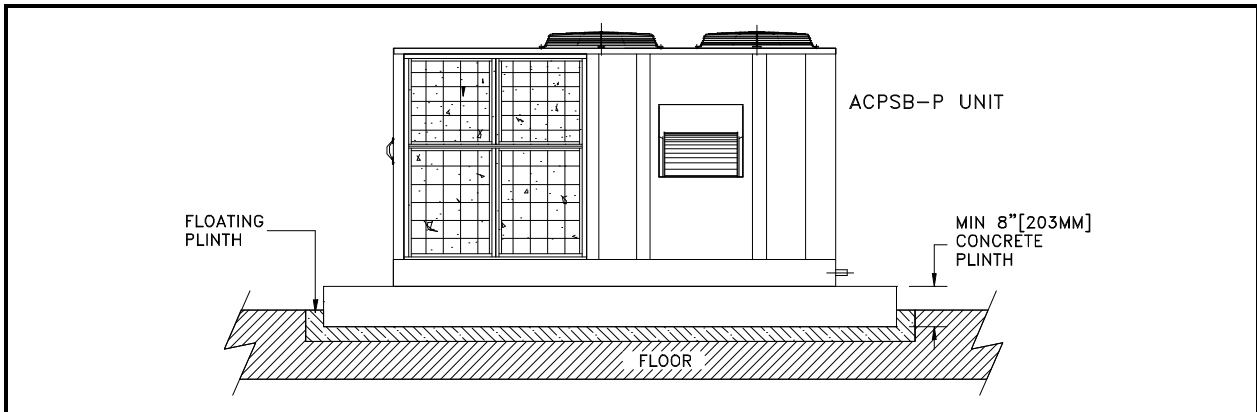
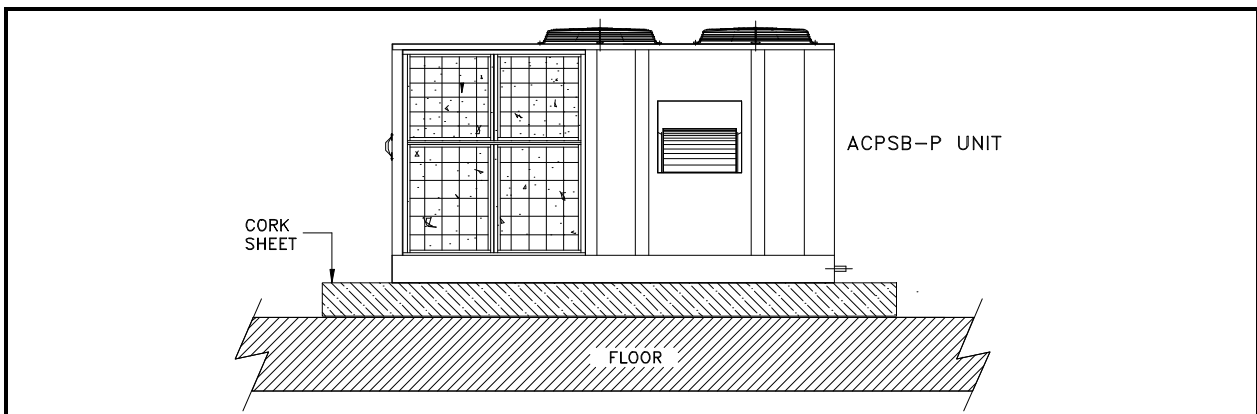

FIGURE 3.1 (b.): PLACE THE UNIT ON A MINIMUM 2½" [63.5MM] THICK CORK SHEET.



3.2 LOCATION

Before installing the unit, care should be given to the following:

- 1.) Installed outside the building.
- 2.) Strong foundation to withstand the unit's weight and vibration. If the base was not leveled, use concrete blocks as base. It is also suggestable to provide rubber pad to isolate the units vibration.
- 4.) Location where air is allowed to circulate. If installing two units together, make sure that the discharge air from one unit were not circuited by the other unit.
- 5.) Location where there is no direct heat such as near a generator. This is because if the entering air temperature is high, then the unit will operate at high condensing temperature and subsequently trip on high pressure.

3.0 INSTALLATION

6.) Location where the unit is not exposed to oily area, salty atmosphere, and sulphide gaseous area.

7.) Location that minimize the ducting length.

Note: Condenser fans are of the propeller type and not suitable for use with ductwork.

3.3 CLEARANCE

Clearance must be provided for (Figure 3.3.)

- 1.) Supply and return air ductwork (where applicable).
- 2.) Electrical power and control wiring.
- 3.) Trapped condensate drain connection.
- 4.) Maintenance and service access to compressor(s), fan motor(s) and drive(s), control panel, filter drier(s), sight glass(es), expansion valve(s), coils and air filter(s).
- 5.) Return air (for free air return).
- 6.) Condenser air discharge.

FIGURE 3.3 AIR COOLED SINGLE PACKAGE AIR CONDITIONER CLEARANCE

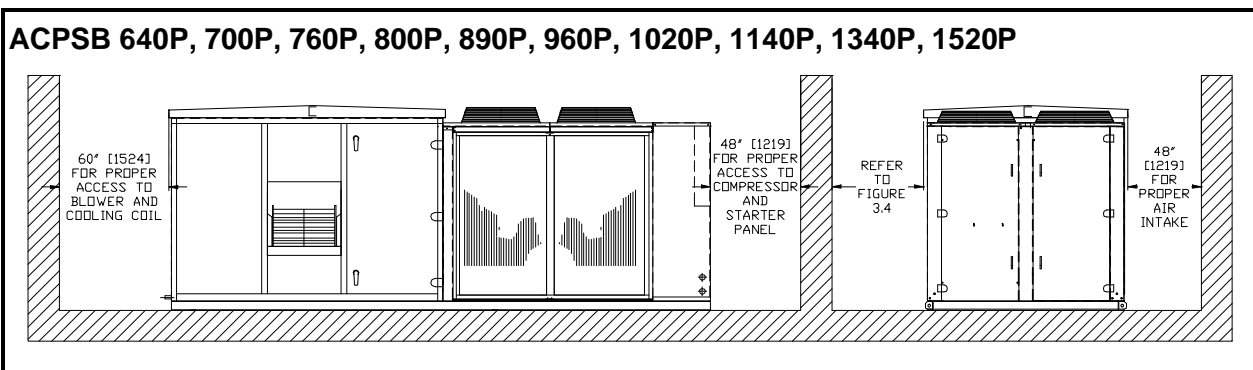
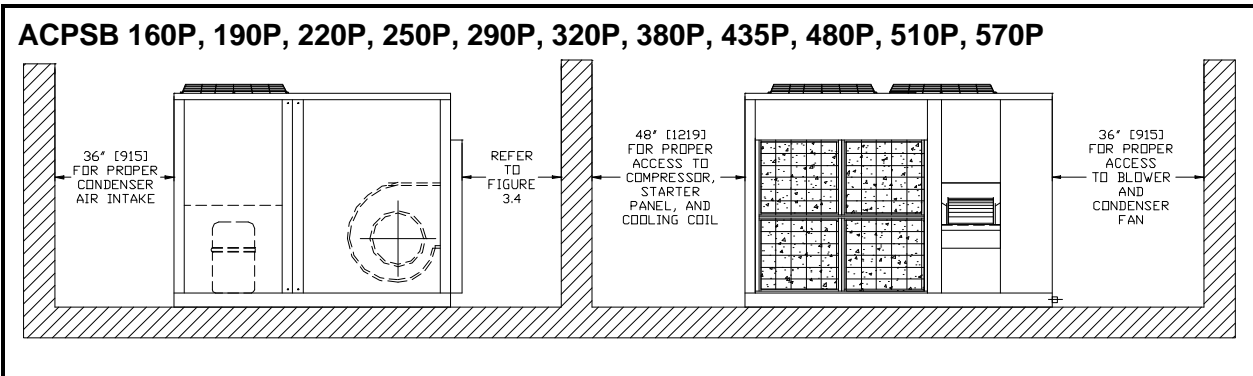
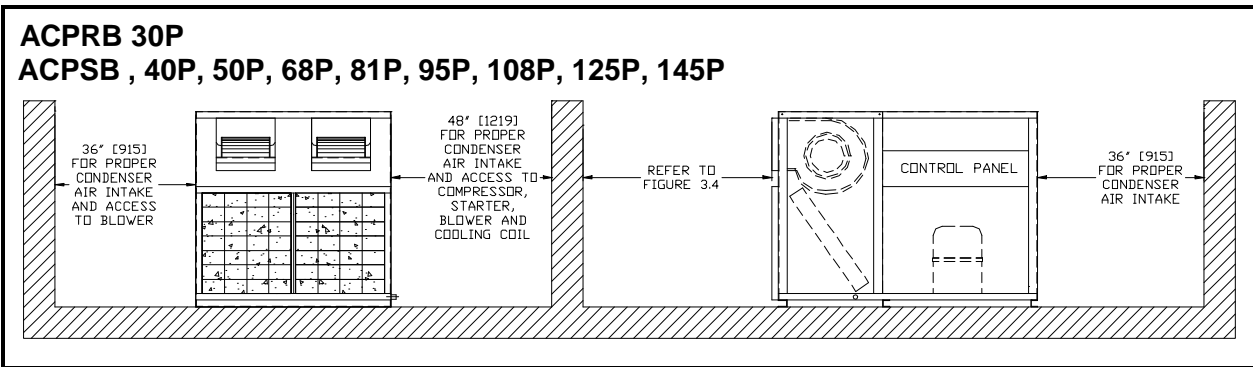

NOTE: ALL DIMENSIONS ARE IN INCHES [MM].

3.0 INSTALLATION

3.4 DUCT CONNECTIONS

All ducts shall be made according to local and/ or national codes and also with good duct installation practice. Minimize static losses by limiting the number of bends.

Suspended duct work with flexible hangers shall not be fastened directly to the unit.

A length of straight duct shall be installed as per Figure 3.4. This is to ensure uniform flow of discharge air. If an elbow need to be installed, then it shall be 1.5 of equivalent duct diameter. (Equivalent duct $\text{Ø} = (4ab/\pi)^{0.5}$).

Please refer to AMCA standard for proper ducting installation/ guidelines.

FIGURE 3.4: SUGGESTED METHOD FOR CONNECTING SUPPLY DUCT

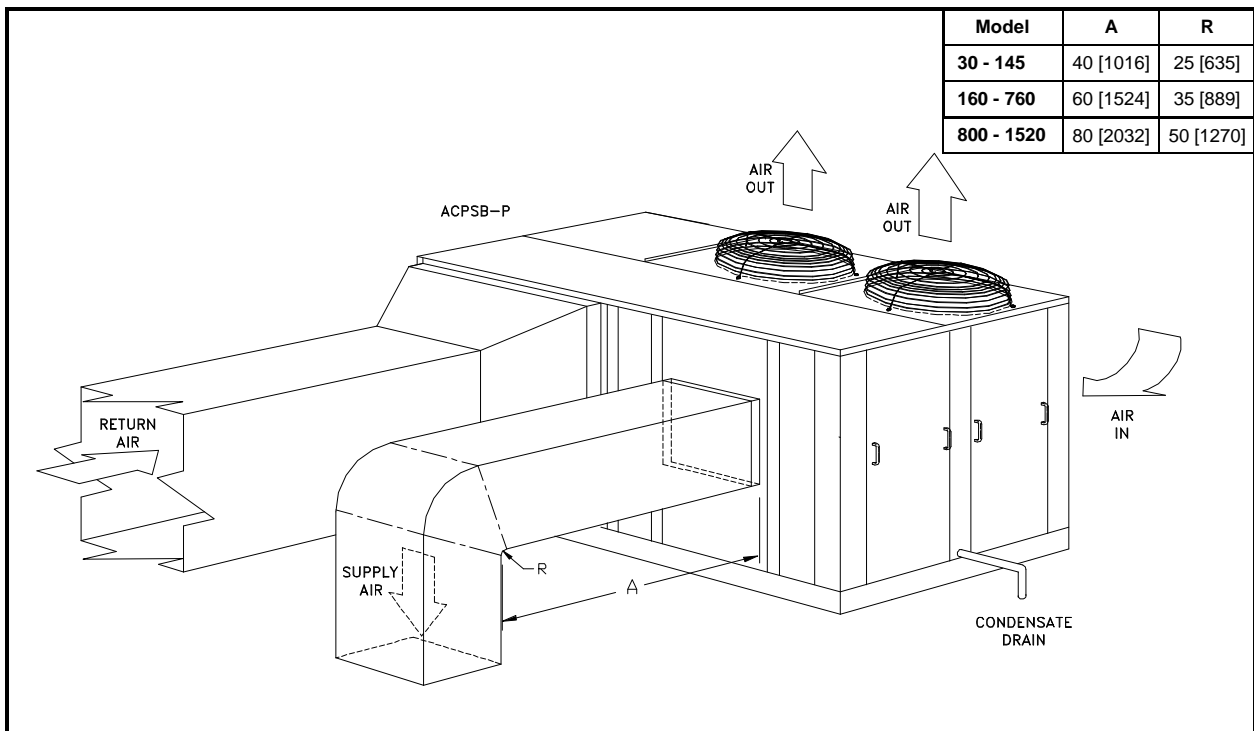

Notes: 1.) Transition element shall not be greater than 15° for converging elements nor greater 7° for diverging element.
 2.) All dimensions are in inches [mm].

3.5 DRAIN CONNECTION

Drain pipe size should be the same or bigger than the existing pipe. The pipe should be installed in downward slope so that water is drained by gravity. A trap must be provided on the pipe so that condensate will drain and not overflowing the drain pan. In addition, the evaporator coil is located before the intake of the centrifugal blowers and operates below atmospheric pressure. Thus, to compensate for this pressure differential, a trap is required.

4.0 OPERATION

4.1 TYPICAL OPERATING SEQUENCE

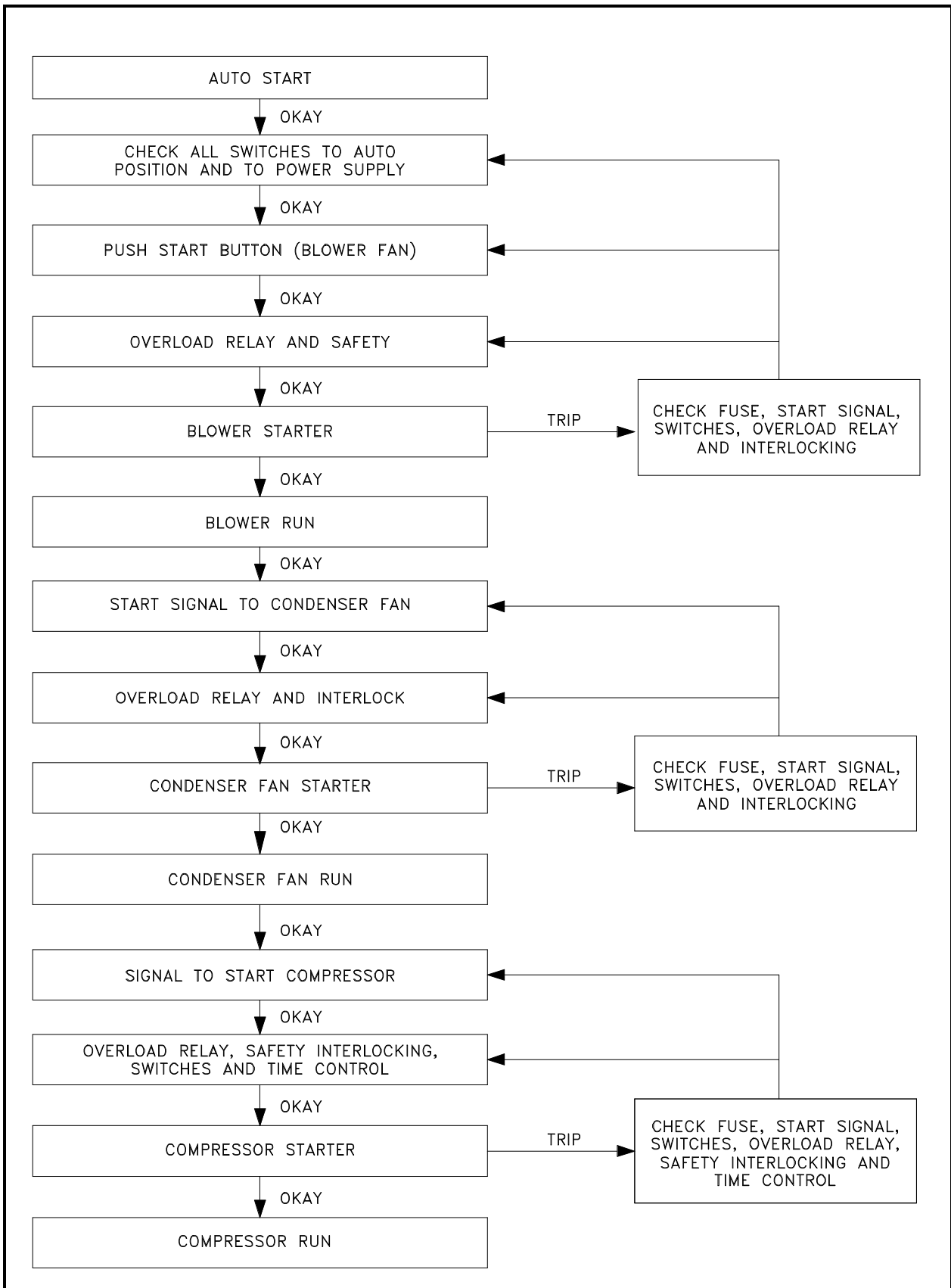

4.0 OPERATION

4.2a TYPICAL WIRING SCHEMATIC - COOLING ONLY

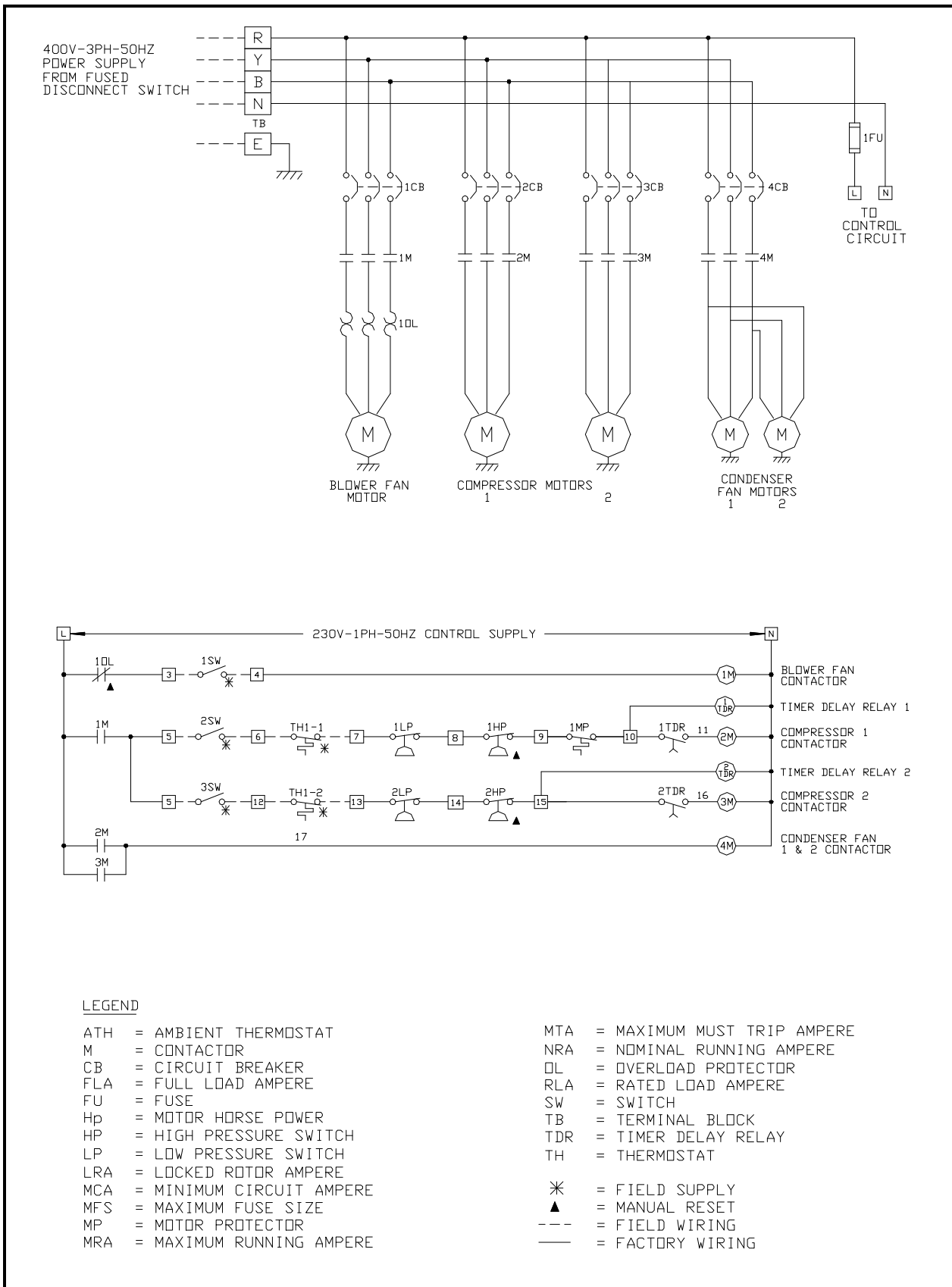

4.0 OPERATION

4.2b TYPICAL WIRING SCHEMATIC - HEAT PUMP

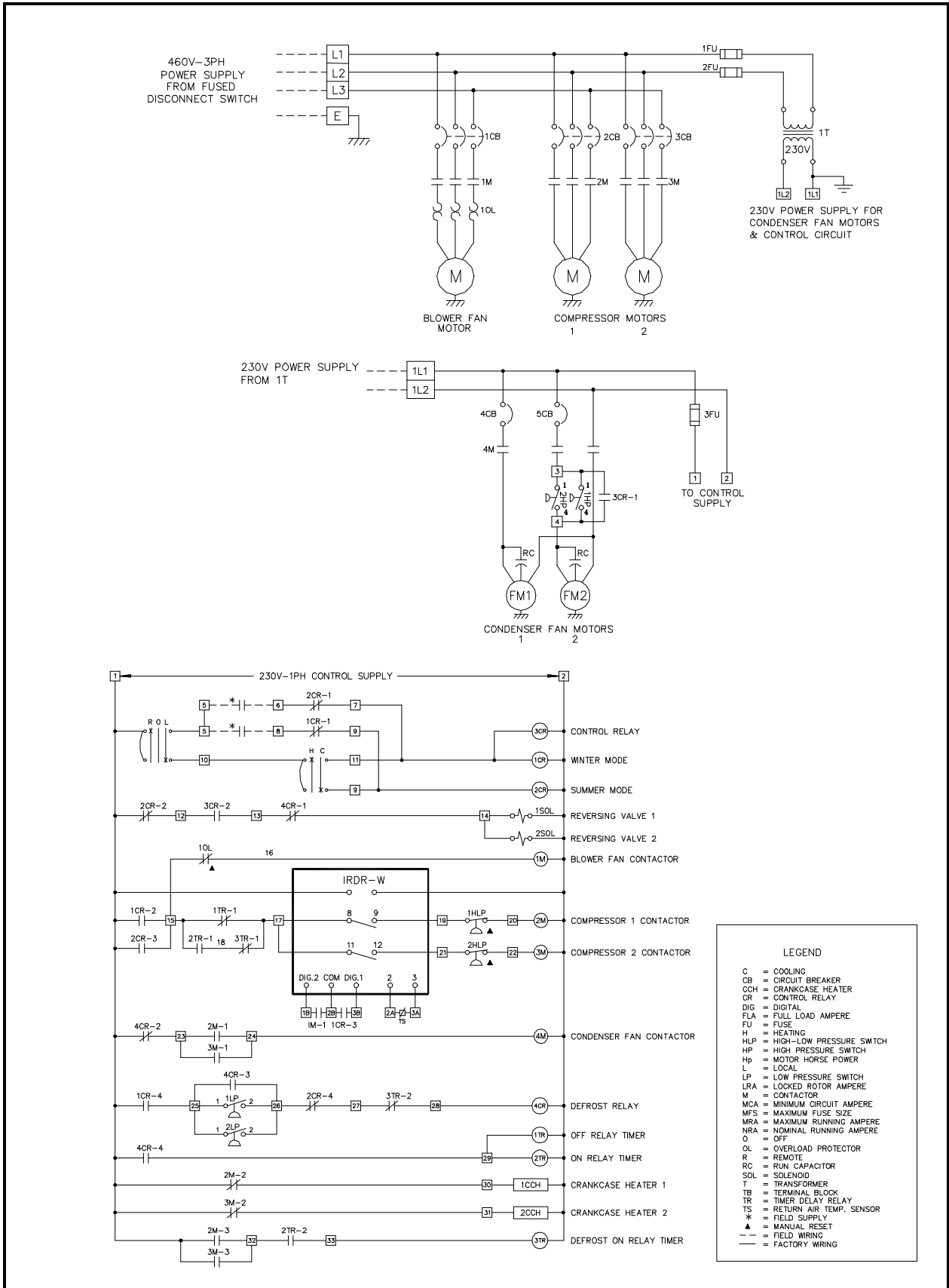

4.0 OPERATION

4.3 PHASE ROTATION

If during initial start up the compressor does not build up pressure, noise is abnormally loud and power consumption is minimal, then there is a possibility that the unit is operating at reverse rotation. Shut down the power and connect phase to the proper terminals.

4.4 CYCLE LIMIT RATE

Each compressors must not be cycle on-off for more than 12 times per hour. The higher number of starts per hour will reduce the life of the compressor. Thus, it is suggested that anti short cycle timer is provided in the system.

4.5 FAN CYCLING (HEAT PUMP)

During cooling only, the head pressure control would allow the unit to operate at lower ambient temperature by building up the discharge pressure through cycling of fans (for single fan unit, this is achievable by reducing the fan speed). If there is demand for cooling, the unit would run on cooling until the manual change over is set to heating. Please observe the lowest ambient for cooling mode.

4.6 DEFROST CYCLE (HEAT PUMP)

During heating, a defrost controller would initiate the defrost cycle once there is demand for it. The sensor from the controller would sense the suction pressure and if the pressure is lower than the preset value, then a signal would be sent to the control panel which then relay the signal to the reversing valve to reverse the cycle. Now, the outdoor coil would be discharging hot air and defrosting the ice on the fins surface. The standard factory set timer for the defrost cycle is 10 minutes which could be adjusted according to the site condition.

4.7 CRANKCASE HEATER (HEAT PUMP)

Refrigerant tend to migrate to colder section of the unit. During winter, the compressor compartment is at lower temperature than the evaporator and thus refrigerant tend to accumulate in the compressor compartment. Connect power source to the unit a few hours prior to compressor start up so that the refrigerant would be forced out of the compressor compartment. It is good practice to let the crankcase heater to be energized continuously, independent of compressor operation.

4.8 STOP VALVE

Inspect all stop valves prior to start up. They shall be in open position.

4.9 HYDROPHILIC CONDENSER COIL (STANDARD FOR HEAT PUMP)

Hydrophilic fins assist condensation to be removed faster and .therefore reduce the possibility of icing on the coil.

4.10 STAINLESS STEEL BOLTS AND NUTS

Reduce the possibility of corrosion especially when the environment is corrosive.

5.0 MAINTENANCE

5.1 MAINTENANCE

The ACPSB-P are designed to provide years of services with minimum maintenance. Nonetheless, it is a good practice to carry out regular inspection and checking to ensure the unit's optimum performance. The following schedule is only meant to be a guide. Actual maintenance schedule for each installation shall depend upon the duty usage, the cleanliness of the surrounding environment, and the cleanliness of the spaced to be air-conditioned.

ITEM	MAINTENANCE PROCEDURE	RECOMMENDED SCHEDULE
Air Filters	<ol style="list-style-type: none"> 1. Washable type. 2. Clean with a vacuum cleaner or tapped lightly and then wash in luke warm water (below 40°C [104°F]). 3. Make sure the filter is dry. 	Once a month or depending upon the condition of the circulated air.
Belt	<ol style="list-style-type: none"> 1. Check the tension and alignment. 2. Move the motor if the belt is loose. 	Once every six months.
Pulley	<ol style="list-style-type: none"> 1. Make sure the set screws are properly tightened and there is no crack on the pulley. 	Once every six months.
Blower	<ol style="list-style-type: none"> 1. Turn the blower manually. It should run smoothly and there is no excessive bearing noise. 	Once every six months.
Bearing and Shaft	<ol style="list-style-type: none"> 1. Check for evidence of wear. 	Once a year.
Bolts, Screws and Nuts.	<ol style="list-style-type: none"> 1. Tighten any loose components. 	Once a year.
Coil	<ol style="list-style-type: none"> 1. Check and remove clogged item between fins. 	Once a year.
Paint	<ol style="list-style-type: none"> 1. Check any evidence of corrosion. 	Once a year.
Compressor	<ol style="list-style-type: none"> 1. Check if there is any leakage. 	Every six months.
Electrical	<ol style="list-style-type: none"> 1. Check voltage, current and wiring. 2. Check connections. 	Every two months.
Drain Pan and Pipe	<ol style="list-style-type: none"> 1. Pour some water into the drain pan and let the water run through. If the pipe is clogged, remove the dirt. 	Every six months.

5.0 MAINTENANCE

5.2 TIGHTENING OF PULLEY SET SCREW

Apply one or two drops of thread locker 243 to the engagement area of set screws before tightening to the pulleys according to the recommended torque.

Set Screw Size - Inches [mm]	Tightening Torque (NM)
5/16 [7.9]	13
3/8 [9.5]	26

5.3 PULLEY ALIGNMENT

- 1.) Insert one end of the string inside the gap between belt and pulley.
- 2.) Rotate the pulley so that string is clipped between the pulley and the belt.
- 3.) Pull the other end of the string as per Figure 5.3.
- 4.) Inspect for any gap between the string and pulley at A and B.
- 5.) If any gap was found, then adjust either pulley to make the gap as small as possible.
- 6.) Repeat steps 1, 2, 3, 4 and 5 for bottom of the same side, top and bottom of the other side. (As shown as Figure 5.4)

Figure 5.3:

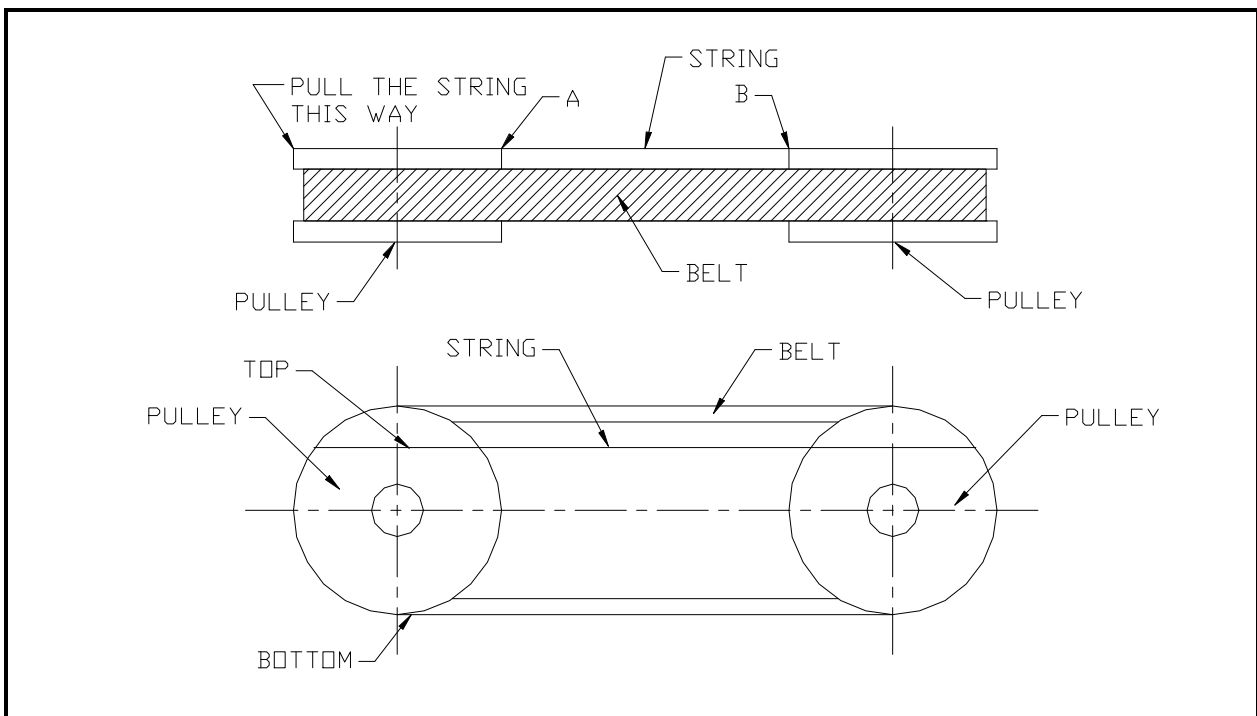

5.0 MAINTENANCE

5.4 BELT TENSION INSPECTION GUIDE

1.) Measure the belt span (See Figure 5.4).

Figure 5.4: Belt Span

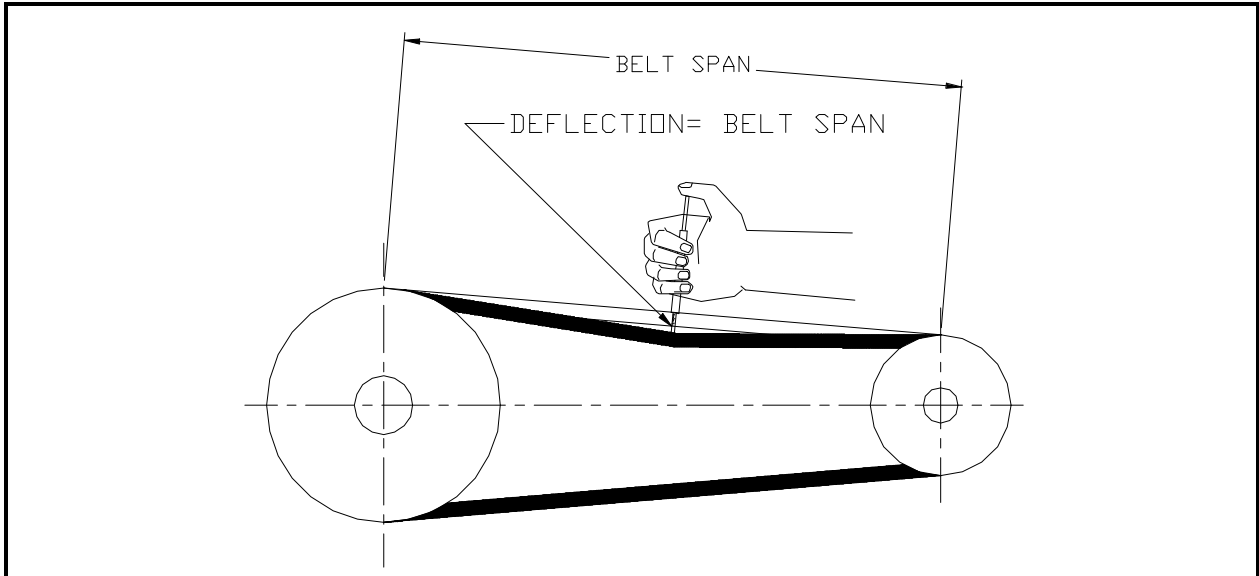

- 2.) Position the “O” ring on the span scale at the measure belt.
- 3.) Set the “O” ring on the deflection force scale to zero.
- 4.) Place the tension meter squarely on the belt at the belt span. Apply a force on the plunger and perpendicular to the belt span until the bottom of the “O” ring even the top of the next belt or with the bottom of a straight edge laid across the sheaves.
- 5.) Remove the tension meter and read the force applied from the bottom of the “O” ring on the deflection force scale.
- 6.) Compare the force you have applied with the values in table 5.4B. and the deflection with table 5.4A.

Note: A new drive should be tensioned to the higher value. After the drive has been running for 30 minutes, the tension should be checked and readjusted to a higher value, if necessary.

Table 5.4A:

Belt Span Lt (cm)	Deflection Td (cm)
25 – 30	0.4
31 – 36	0.5
37 – 42	0.6
43 – 48	0.7
49 – 54	0.8
55 – 60	0.9
61 – 66	1.0
67 – 72	1.1
55 – 60	1.2
79 – 84	1.3
85 – 90	1.4
91 – 96	1.5
97 – 102	1.6
103 – 108	1.7
109 – 114	1.8

5.0 MAINTENANCE

Table 5.4B:

Belt Type	Small Pulley Diameter - Inches [mm]	Maximum Deflection - Lbs [Kg]
A	3.0 – 5.5 [76 - 140]	2.2 - 3.3 [1.0 – 1.5]
B	5.0 – 8.0 [140 - 203]	3.3 - 6.8 [2.0 – 3.1]
C	8.0 – 16.0 [203 - 406]	9.0 - 13.4 [4.1 – 6.1]

5.5 LEAK TEST (SYSTEM PRESSURE TEST)

- 1.) Leak test pressure is at 200 psig [1380 kPa]. Disconnect or shut off all valves which may be damaged by 200 psig [1380 kPa] test pressure.
- 2.) Open all valves in system so that entire system can be pressurized and connect refrigerant cylinder to charging connection.
- 3.) Charge in freon vapor to the only in system. Partially charge the systems until 50 psig [345 kPa] and then pressurize with dry nitrogen until 200 psig [1380 kPa]. Stop charging gas if noise of escaping gas is heard. Skip to sequence (6.)
Caution: Always use inert gas such as Nitrogen for testing. Never use other gases such as Oxygen or acetylene which may be flammable.
- 4.) With pressure at 200 psig [1380 kPa], shut off the valve connecting nitrogen cylinder to the system. Disconnect nitrogen cylinder and leave pressure gauge indicating 200 psig [1380 kPa] connected to system.
- 5.) With halide torch or electronic leak detector, leak check every flange, joint, relief valve, pressure control, coils and headers. Mark every leak and record down as remarks.
- 6.) When all leaks have been found, release the charge to prevent refrigerant accumulation around the system.
- 7.) Repair all leaks (check off on your remarks): If rebrazing is required, feed nitrogen through into the system at slightly excessive pressure (leave system open and make sure nitrogen flows through).
- 8.) After repairing leaks, re-check as per procedure 1 through 7.
- 9.) When system tight after leak test, keep pressurized at 200 psig [1380 kPa] and hold for 12 hours. Drops in pressure should be negligible (some may be due to temperature change only.)
- 10.) Leak check again.
- 11.) When system is tight, proceed with vacuum test and dehydration.

5.6 VACUUM TEST AND DEHYDRATION

The purpose of evacuation is to evacuate the system when it is known or suspected that the system has been exposed to atmosphere, and there is a possibility that moisture has entered the system.

- 1.) Blow-off charge or pump down the refrigerant.
- 2.) Connect vacuum pump to the liquid line valve and carefully check the unit piping to ensure all passages are open. (NEVER USE SYSTEM COMPRESSOR TO EVACUATE).
- 3.) Start vacuum pump operation and pull vacuum to about 2 to 2.5 mm Hg [0.26 to 0.33 kPa] absolute pressure. During evacuation the pressure may remain steady for sometime at about 0.5 inch or 12 mm Hg [1.69 kPa] absolute pressure. This is caused by moisture evaporating in the system. This "boiling off" or "evaporation period" last about the same time as it took from initial start to reach this point.

5.0 MAINTENANCE

- 4.) When the "boiling off" period lasts longer than indicated under 3, break vacuum with refrigerant or nitrogen gas to sweep moisture out and evacuate and dryer shells, etc., up to a temperature of 100°F [37.8°C].
- 5.) Break vacuum with refrigerant or nitrogen gas until pressure is 0 psig [0 kPa].
- 6.) Re-evacuate to 1 mm Hg [0.133 kPa] absolute pressure.
- 7.) Disconnect vacuum pump and leave system standing for 6 hours. There should be no change in vacuum during this period. If there is a change repeat 1 to 7.

5.7 REPLACEMENT OF DRIERS OR SIGHT GLASS

- 1.) Break vacuum with nitrogen.
- 2.) When permanently brazed drier or sight glass is used, open one valve on system to atmosphere while maintaining slight nitrogen flow.
- 3.) When flare connected drier or sight glass is used, use similar procedure as under 2. However, no valve need to be left open to atmosphere.
- 4.) When replaceable dryer core is used follow procedure as under 3. Insert drier core(s). Tighten cap screws.
- 5.) Re-evacuate system to 1 mm Hg [0.133 kPa] absolute.

5.8 CHARGING

- 1.) Connect refrigerant cylinder through charging connection to charging valve.
- 2.) Loosen flare nut on other end of charging connection and blow air out with refrigerant. Tighten flare nut on charging connection.
- 3.) Weight refrigerant cylinder.
- 4.) Open charging valve and charge in refrigerant vapor through suction access valve until about 150 psig [1034 kPa]. Switch to liquid line access valve and charge in liquid refrigerant. Continue charging with liquid refrigerant until clear glass is observed.
- 5.) Shut off refrigerant charging valve but keep connected. Check charging valve flare nut for leak. Check and record down discharge and suction pressure. If more than one system to be charged, follow procedure 1 through 4 for each system. After all the systems have been done up to step 4, proceed with 5 and 6.
- 6.) Shut off the system (compressor, fans, pumps) and leave for 24 hours.

5.9 LUBRICATION

The scroll compressor use mineral oil 3GS for R22 compressors and POE (Polyol ester) oil for HFC refrigerants (R134a, R407c etc) compressors. Please refer to compressor name plate for original oil charge. Recharging shall be 118ml less than the original charge. If the condenser fan uses a direct-drive permanent split capacitor motor. The motor should be lubricated with 30 to 40 drops of SAE # 20 non-detergent oil as follows depending on service:

- LIGHT DUTY** -After 25,000 operating hours.
NORMAL DUTY -Annually after three years or 8,000 operating hours.
HEAVY DUTY -Annually after one year or at least every 1500 operating hours.

CAUTION: DO NOT OVER OIL

5.0 MAINTENANCE

5.10 TROUBLE SHOOTING CHART

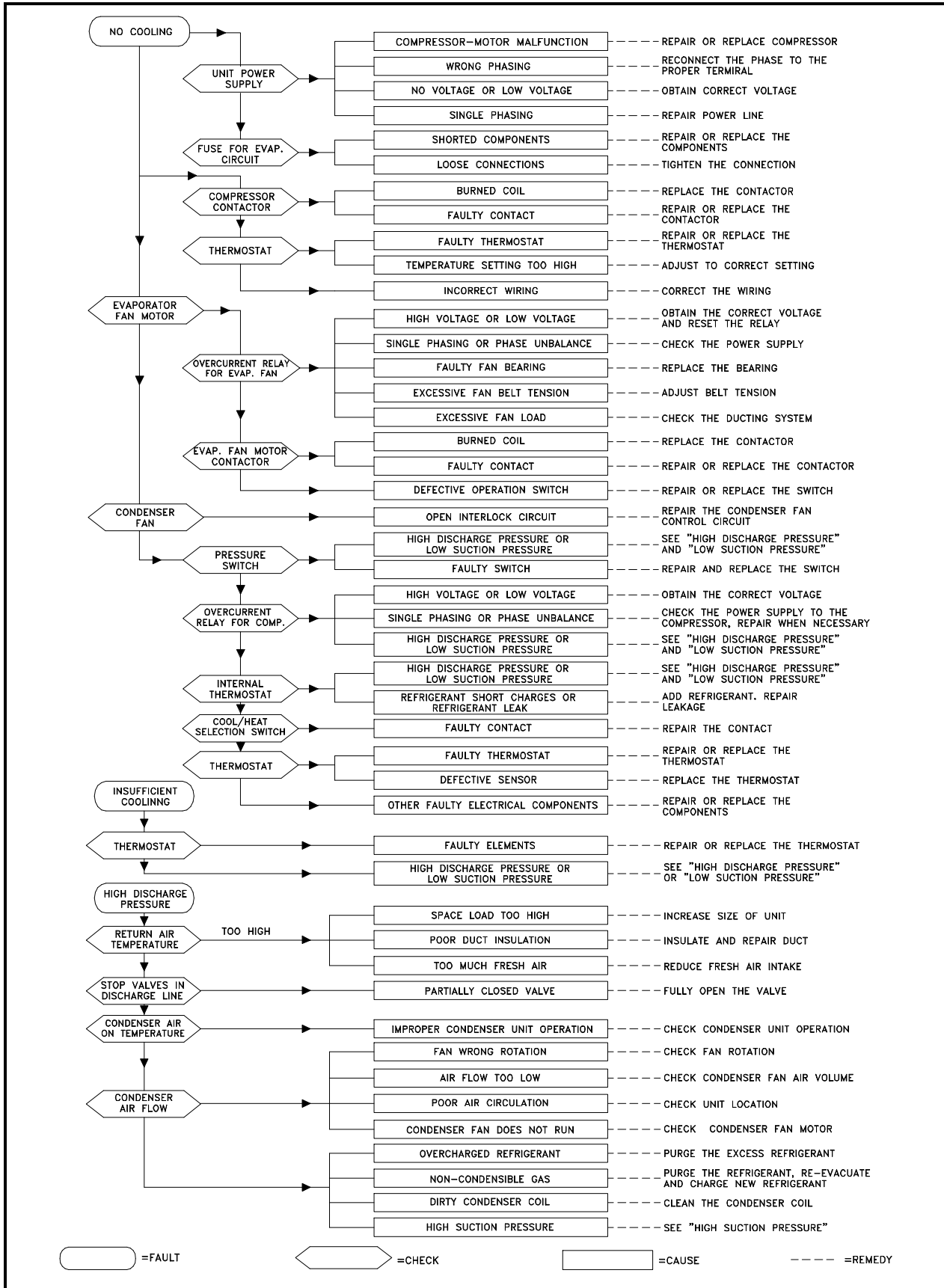

5.0 MAINTENANCE

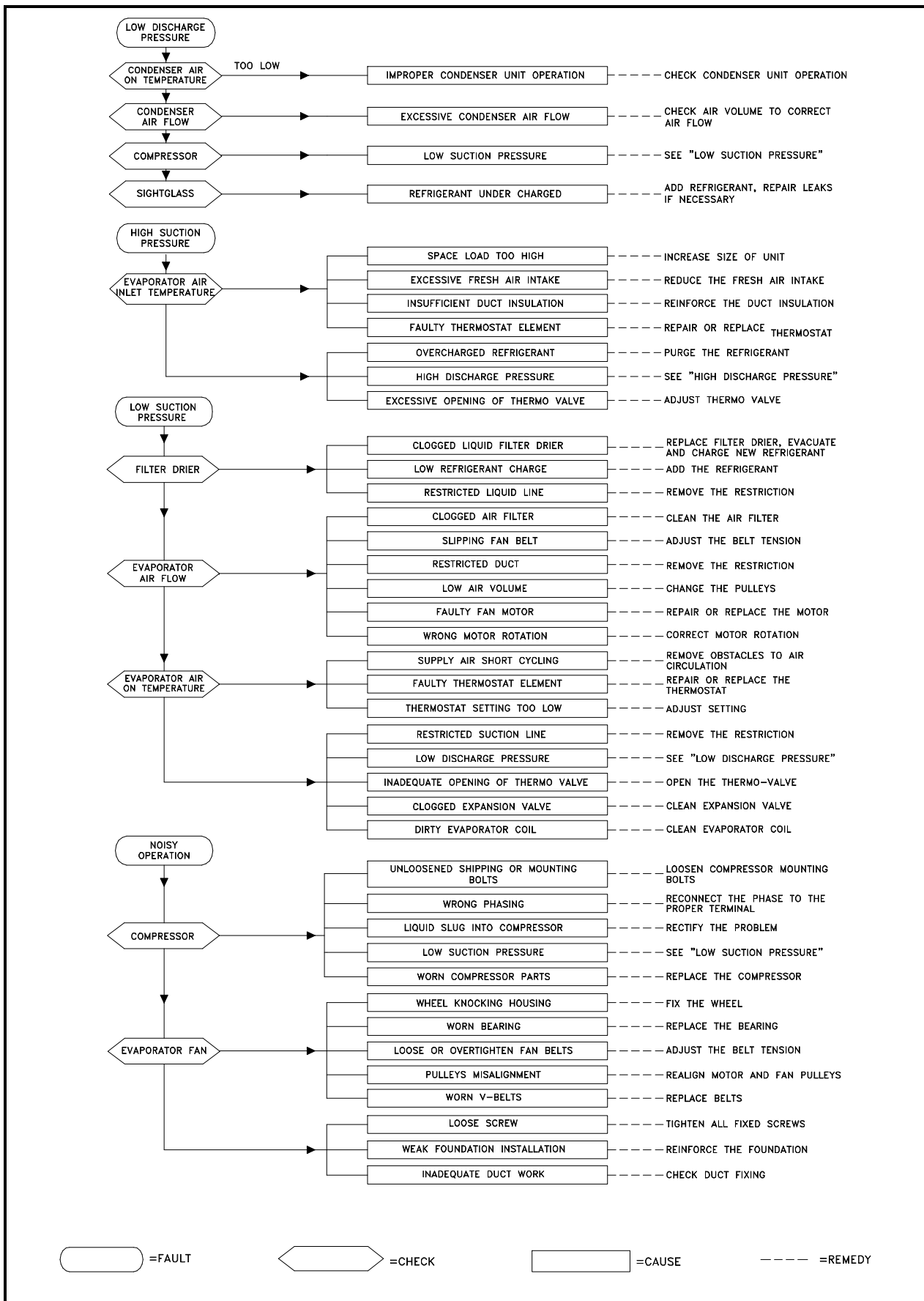

5.0 MAINTENANCE

5.11 SAMPLE LOG SHEET

SHEET NO.....

DUNHAM-BUSH AIR COOLED PACKAGE UNIT

UNIT MODEL NO. UNIT NO. VOLTS: Hz

UNIT SERIAL NO.

START UP : DATE TIME

DATE									
TIME									
COMPRESSOR NO.									
SUCTION PRESSURE	1.								
	2.								
	3.								
	4.								
SUCTION TEMPERATURE	1.								
	2.								
	3.								
	4.								
DISCHARGE PRESSURE	1.								
	2.								
	3.								
	4.								
DISCHARGE TEMPERATURE	1.								
	2.								
	3.								
	4.								
DISCHARGE SUPERHEAT (SAT. DISCH.- DISCH. TEMP.)	1.								
	2.								
	3.								
	4.								
SUCTION SUPERHEAT (SAT. SUCT.- SUCT TEMP.)	1.								
	2.								
	3.								
	4.								
RETURN AIR TEMPERATURE – DB/WB									
SUPPLY AIR TEMPERATURE – DB/WB									
AIR VOLUME									
AMBIENT AIR TEMPERATURE									
OFF CONDENSER AIR TEMPERATURE									
COMPRESSOR AMPS	1.								
	2.								
	3.								
	4.								
CONDENSER FAN AMPS									
EVAPORATOR FAN AMPS									
VOLTS									

This log sheet is provided as a recommendation of the readings that should be taken on a periodic basis. The actual readings taken and the frequency will depend upon the units application, hours of use, etc. This type of information can prove very useful in preventing and/ or solving problems that might occur during the life of the unit.

5.0 MAINTENANCE

5.12 DUNHAM-BUSH STARTUP REPORT

AIR COOLED CONDENSING UNITS & PACKAGED UNITS

SITE INFORMATION

Job Name _____ Installing Contractor _____
 Address _____
 Unit No. _____ Unit Location _____ Area Served _____

NAMEPLATE DATA

Unit Details

	<u>Model</u>	<u>Serial No.</u>	<u>Factory Order</u>
Indoor or Packaged Unit	_____	_____	_____
Outdoor Unit (<i>Remote Condenser</i>)	_____	_____	_____

Blower Motor

Model _____ Serial No. _____ Manufacturer _____
 Volt _____ Phase _____ Hz _____ FLA _____ LRA _____
 RPM _____ kW/HP _____ Type _____

Compressors

	<u>Compressor 1</u>	<u>Compressor 2</u>	<u>Compressor 3</u>
Model	_____	_____	_____
Serial No.	_____	_____	_____
V / Ph / Hz	_____ / _____ / _____	_____ / _____ / _____	_____ / _____ / _____
FLA / LRA	_____ / _____	_____ / _____	_____ / _____

Condenser Fans (Air Cooled & Remote Condenser)

	<u>Model</u>	<u>Serial No.</u>	<u>General</u>
1)	_____	_____	Volt _____
2)	_____	_____	Phase _____
3)	_____	_____	Hz _____
4)	_____	_____	FLA _____
5)	_____	_____	LRA _____
6)	_____	_____	HP/kW _____

BLOWER & COIL

Blower Section

Blower Model _____ Size _____ Fan Belt Model _____
 Blower Pulley Model _____ Size _____ Fan Belt Size _____
 Motor Pulley Model _____ Size _____ Quantity _____

Coil Section

Coil Material Aluminium Copper Hydrophilic
 Coil Arrangement FPI _____ Length _____ Height _____ # Rows _____
 Filter Type _____ Filter Size 1) _____ X _____ # Filters _____
 2) _____ X _____ # Filters _____
 3) _____ X _____ # Filters _____

5.0 MAINTENANCE

ELECTRICAL

	<u>Contactors</u> Model / Rating	<u>Serial No.</u>	<u>Qty</u>	<u>Type of Starters</u>	
Blower Fan	_____	_____	_____	<input type="checkbox"/> DOL	<input type="checkbox"/> SD / AT
	_____	_____	_____		
Comp. 1	_____	_____	_____	<input type="checkbox"/> DOL	<input type="checkbox"/> SD / AT
	_____	_____	_____		
Comp. 2	_____	_____	_____	<input type="checkbox"/> DOL	<input type="checkbox"/> SD / AT
	_____	_____	_____		
Comp. 3	_____	_____	_____	<input type="checkbox"/> DOL	<input type="checkbox"/> SD / AT
	_____	_____	_____		
Cond. Fan 1	_____	_____			
Cond. Fan 2	_____	_____			
Cond. Fan 3	_____	_____			
Cond. Fan 4	_____	_____			
Cond. Fan 5	_____	_____			
Cond. Fan 6	_____	_____			

Winding Insulation Test

<u>Blower Motor</u>	<u>Compressor 1</u>	<u>Compressor 2</u>	<u>Compressor 3</u>
L1 _____ MΩ	L1 _____ MΩ	L1 _____ MΩ	L1 _____ MΩ
L2 _____ MΩ	L2 _____ MΩ	L2 _____ MΩ	L2 _____ MΩ
L3 _____ MΩ	L3 _____ MΩ	L3 _____ MΩ	L3 _____ MΩ

Note :

Type apostrophe ' ahead of serial number when serial number appears as ##.
 Example: Type '123457890 for 1234567890.
 The Startup Report must be duly completed and copied to Dunham-Bush.
 The Startup Report applies to various models. Fill in where applicable.
 This list may be incomplete. Please fill setpoint in miscellaneous section if undefined.

DISCLAIMER

Failing to submit your Startup Report and Logsheets within (2) weeks from the date of startup will invalidate factory warranty on the whole unit.
 Please submit your startup report to the following address for warranty registration.

Attn : The Administrator (Global Service)

Dunham-Bush Holding Bhd

Lot 5755-6, Kidamai Industrial Park, Bukit Angkat, 43000 Kajang, Selangor Darul Ehsan, MALAYSIA
 Tel: (603) 8733 9898, Fax: (603) 8734 2178, 8734 6178
 E-mail: global@dunham-bush.com

5.0 MAINTENANCE

5.13 STARTUP CHECK LIST

- | | | |
|---|------------------------------|-----------------------------|
| 1) Shipping, Transportation, Installation, Handling, or any other damages? | <input type="checkbox"/> Yes | <input type="checkbox"/> No |
| 2) Short shipped components or accessories? | <input type="checkbox"/> Yes | <input type="checkbox"/> No |
| 3) Unit installed in accordance with the technical specifications provided? | <input type="checkbox"/> Yes | <input type="checkbox"/> No |
| 4) Steel brackets or wooden blocks against transportation damage removed? | <input type="checkbox"/> Yes | <input type="checkbox"/> No |
| 5) Bower wheel mounted onto the shaft and setscrews tightened firmly? | <input type="checkbox"/> Yes | <input type="checkbox"/> No |
| 6) Blower shaft mounted onto the bearings and setscrews tightened firmly? | <input type="checkbox"/> Yes | <input type="checkbox"/> No |
| 7) Blower pulley and motor pulley aligned and setscrews tightened firmly? | <input type="checkbox"/> Yes | <input type="checkbox"/> No |
| 8) Bearings mounted firmly onto the framework or structure? | <input type="checkbox"/> Yes | <input type="checkbox"/> No |
| 9) Fan belt of the same size and type. Belt tension checked and acceptable? | <input type="checkbox"/> Yes | <input type="checkbox"/> No |
| 10) Motor bracket fastened firmly onto the rail without any loose motion? | <input type="checkbox"/> Yes | <input type="checkbox"/> No |
| 11) Motor and shaft bearings greased and lubricated? | <input type="checkbox"/> Yes | <input type="checkbox"/> No |
| 12) Rotating parts free to rotate whenever they are rotated manually? | <input type="checkbox"/> Yes | <input type="checkbox"/> No |
| 13) Drain pipe and "U" trap installed? | <input type="checkbox"/> Yes | <input type="checkbox"/> No |
| 14) Permanent return air filters or any other temporary filters installed? | <input type="checkbox"/> Yes | <input type="checkbox"/> No |
| 15) Any object or rubbish that would be sucked into the blower removed? | <input type="checkbox"/> Yes | <input type="checkbox"/> No |
| 16) Motor resistance above minimum resistance required for startup? | <input type="checkbox"/> Yes | <input type="checkbox"/> No |
| 17) Incoming power supply tested for correct phase sequence, voltage, etc? | <input type="checkbox"/> Yes | <input type="checkbox"/> No |
| 18) Setpoints verified and control sequence tested for functionality? | <input type="checkbox"/> Yes | <input type="checkbox"/> No |
| 19) Fan motor tested for correct rotation. Current drawn less than 1.1 x FLA? | <input type="checkbox"/> Yes | <input type="checkbox"/> No |
| 20) Compressor tested for correct rotation and functionality? | <input type="checkbox"/> Yes | <input type="checkbox"/> No |
| 21) Sign of vibration or abnormal noise? | <input type="checkbox"/> Yes | <input type="checkbox"/> No |
| 22) Sign of air leakage or condensation? | <input type="checkbox"/> Yes | <input type="checkbox"/> No |

5.0 MAINTENANCE

5.14 OPERATING PARAMETERS

Job Name _____ Unit Model _____ Date _____
 Job Location _____ Unit Serial No. _____ F/O _____

			Actual	Controller Setpoint	-
GENERAL	Room Temperature °C				-
	Evaporator	On Coil	(Dry Bulb) °C	-	-
			(Wet Bulb) °C	-	-
	Off Coil	(Dry Bulb) °C	-	-	
		(Wet Bulb) °C	-	-	

			System 1	System 2	System 3	
SYSTEM	Pressure	Suction Pressure bar				
		Disch. Pressure bar				
		Liquid Pressure bar				
	Temp	Suction Temp °C				
		Disch. Temperature °C				
		Liquid Temperature °C				
	SSH	Suction Superheat °C				
		Disch. Superheat °C				
		Subcooling °C				
	Condenser	On Coil	(Dry Bulb) °C			
			(Wet Bulb) °C			
		Off Coil	(Dry Bulb) °C			
(Wet Bulb) °C						

		System 1	System 2	System 3	
ELECTRICAL	Amperage	Blower Fan A	-	-	
		Compressors A	System 1	System 2	
		Condenser Fans A	1	2	3
	Voltage	L1-L2 V	4	5	6
		L1-L3 V			
		L2-L3 V			

REMARKS

DETAILS OF STARTUP ENGINEER

CUSTOMER ACCEPTANCE OF STARTUP

SIGNATURE

SIGNATURE

NAME/TITLE

NAME/TITLE

COMPANY

COMPANY

ADDRESS

ADDRESS

CONTACT NO.

CONTACT NO.

MANUFACTURER RESERVES THE RIGHT TO CHANGE SPECIFICATION OR DESIGN AT ANY TIME WITHOUT PRIOR NOTICE.

DUNHAM-BUSH

Products that perform...By people who care

7001170209
(01-09)